

Omega I60

User Manual

Contents

Introduction	4
Warranty	4
Product Warranty Period	4
Conditions to exercise the warranty	5
How to exercise the warranty?	5
Warranty exclusions	6
Limitations and liability exemptions	7
Specifications	9
Diagrams	12
Safety and compliance	14
General information	14
Hazards	14
Intended use	14
Remove flexible printin surface	14
Explanation of safety symbols	15
Door locks	16
Emergency Stop	17
Andon Light	17
Proper area to install the printer	18
Moving the machine	19
Installation	20
What is in the box?	20
Unboxing	21
Basic Setup	23
Connecting the printer	25
Register the printer	26
New user	27
Existing user	27
Offline mode	28
User interface	29
Overview	29
Navigation menu	29
Printing screens	30
Print files	30
Printer setup	31
Print heads - Preheat	31
Print heads - Change hotend tip	32

Build plate - Preheat	33
Build plate - Move platform	33
Build plate - Build plate leveling	34
Material Operation System (MOS)	35
BCN3D Omega Materials	36
Loading	37
Unloading	38
Drying cycle	39
Passive mode	40
Exit Passive mode	40
Settings	41
General	41
Calibration	41
Z Axis calibration	42
XY Axes calibration	43
Operation	45
Preparing a print	45
BCN3D Stratos	45
Add printer	46
Printing modes	46
Dual	48
Single 1 and Single 2	49
Duplication	50
Mirror	51
Maintenance	52
Maintenance schedule	52
Replacement parts	53
Maintenance routines	54
BCN3D Technical Assistance Services	55
Technical Assistance	55
Terms and conditions	56
Overall vision	56
Return policy	56
How to make a return	57
Open Source	58

Introduction

Warranty

Technical Support

For any questions or problems with BCN3D Products, please contact us at:

Carrer de Miquel Servet, 18
08850 Gavà, Barcelona (España)
Email: omega-assistance@bcn3d.com
Tel: +34 935 95 43 43

BARCELONA THREE DIMENSIONAL
PRINTERS, S.L.
VAT: ESB67235069
Manufactured in Spain

List of Consumable components

This document lists the Consumable components that, due to their natural deterioration, are excluded from the Warranty: **Hotend tips, Print heads, Teflon tubes, Build plate assembly, Flexible printing surface, Filament spools, Printing adhesive (Magigoo), Printed parts, HEPA/Carbon filter.**

Warranty extension

BCN3D offers a warranty extension service for the BCN3D Omega I60, allowing you to extend coverage for up to 3 years.

The warranty extension provides the same coverage and benefits as the standard one-year warranty included with the product.

For more information on how to purchase the warranty extension, please contact BCN3D or your local partner.

BARCELONA THREE DIMENSIONAL PRINTERS, S.L. provides this Warranty to the consumers of the BCN3D brand products included in the sales package ("Product").

This Warranty will be valid only in the country in which the sale of the Products has been made. BARCELONA THREE DIMENSIONAL PRINTERS, S.L. hereby guarantee that, within the warranty period, BARCELONA THREE DIMENSIONAL PRINTERS, S.L. or an authorized service company will correct, within a reasonable period of time, the defects of materials or manufacturing detected in the Products, according to the clauses set out below.

Consumer purchases within the European Union are governed by applicable mandatory consumer protection legislation, including Directive (EU) 2019/771 and its national implementations, including Royal Legislative Decree 1/2007 as amended by Royal Decree-law 7/2021 in Spain.

Purchases made by professionals, companies, educational institutions, industrial operators or entities acting within their trade, business or professional activity ("Professional Customers") shall not be considered consumer purchases and shall be governed by the applicable provisions of the Spanish Civil Code and Commercial Code together with the commercial warranty set forth herein.

For Professional Customers, BCN3D grants a limited commercial warranty of twelve (12) months from invoice date covering manufacturing defects under normal, proper and intended industrial use conditions.

This commercial warranty is exclusive to Professional Customers and replaces any implied warranties to the maximum extent permitted by applicable law.

Product Warranty Period

Consumer purchases within the European Union are subject to the statutory warranty period established under applicable consumer protection legislation.

Professional or business purchases are covered by a commercial warranty period of twelve (12) months from invoice date, unless otherwise agreed in writing.

The warranty will come into force from the date on which the product was purchased for the first time by the end customer (invoice date). If you do not have the purchase invoice, the manufacturing date of the product registered by BCN3D Technologies will be considered as

the beginning of the warranty period.

Conditions to exercise the warranty

The BCN3D warranty is granted under the following conditions:

- 1** Acquire the product through BCN3D Technologies or one of its authorized resellers (See <https://www.bcn3d.com/en/reseller/> to see the addresses of authorized BCN3D Distributors).
- 2** Be within the established deadlines, which are:
 - **1 year** from the invoice date for purchases within the EU.
 - **1 year** from the invoice date for purchases outside the EU.
- 3** The product must be packed in its original packaging. Otherwise, BCN3D Technologies reserves the right to accept or reject the return, or if it is estimated, a depreciation of the product.
- 4** The product has been sold as new, not as reconditioned or used.
- 5** The serial number of the product to be returned

will have to correspond to the one in the BCN3D Technologies records.

6 Unless specifically requested by BCN3D Technologies, nothing else should be sent apart from the Product. All accessories and removable storage devices such as SD memory cards must be removed from the product. BCN3D Technologies is not responsible for the loss, damage or destruction of accessories or removable storage devices, unless caused intentionally or negligently by BCN3D Technologies.

7 BCN3D recommends the use of materials from the BCN3D Omega I60 portfolio as well as those that are part of the OFN (Open Filament Network). These materials have been tested to provide customers with an appropriate printing profile that ensures correct printing. However, customers may use third-party materials, accessories, etc., as this does not void the warranty.

The parts affected by the improper use of third-party materials will be excluded from the warranty.

8 If a part of the Product is repaired or replaced during the warranty period, the remaining warranty period for the entire product will apply to this part. However, repairing and / or replacing a part will not extend the warranty period.

9. The purchaser shall inspect the Product immediately upon delivery and notify any apparent defect in writing within five (5) business days from receipt.

BCN3D Technologies official Distributors are responsible for the warranty on behalf of BCN3D Technologies. Therefore, any warranty notification must be made directly to the BCN3D Technologies official Distributor where the product was originally purchased.

Any warranty claim must first be acknowledged and accepted, either by BCN3D Technologies or by a Distributor of BCN3D Technologies. The Distributor

is obliged to rectify any damage for free according to this guarantee. In the event that the defect can not be repaired, the Distributor, within the warranty period, will replace the Product for an identical product, or if the product is no longer manufactured, for a similar product of the same value or offer an adequate refund.

Depending on the country, the warranty may not automatically include the costs incurred for the shipping of the defective Products for repair or replacement.

How to exercise the warranty?

In order to exercise the warranty, you will have to contact us to omega-assistance@bcn3d.com.

1 You will receive a document by email to be completed (RMA), so that we can authorize the reparation.**2** Once the RMA is completed, you must send it to omega-assistance@bcn3d.com duly completed.

3 The technical support department will assess the situation and within 48 hours will tell you whether or not we accept your return request. If accepted, it will assign you an RMA number with a validity of 30 days.

4 The product must be sealed in its **original packaging**. In the case of not returning the order in its original and sealed packaging, BCN3D Technologies reserves the right to accept or reject the return or establish a depreciation of the product.

5 Once the product has been packed, we will send a transporter that will pick up the goods to be returned perfectly packed, being able to desist from the collection in case of improper packing. It is important that you place the **RMA number visible on the package**.

6 Once the goods are received in our facilities, our technical service will inspect them and determine whether the product is covered by warranty or not.

7 If the user does not accept the reparation, BCN3D Technologies will return the product by the agreed

method of RMA. If the user does not collect the product, or if it can not be sent to the address provided by the user, BCN3D Technologies will contact the user by the means that he considers convenient and previously provided. If the user does not collect the product during the 90 days following the moment of sending the information, BCN3D Technologies reserves the right to invoice the cost of storage, disposal of the product according to the applicable laws and regulations, and any law for non-payment.

Warranty exclusions

This Warranty does not cover:

1 Defects caused by inappropriate transportation (without original packaging) or handling of the Product (including without limitation, defects caused by sharp elements, cutting, bending, compression or fall).

2 The wear and tear caused by the use of the Product, including, but not limited to, the wear of moving parts, control panels or elements that interact with the operation of the Product.

3 The damages caused by the non-compliance of the maintenance plan exposed in the User's Manual of the Product.

4 The malfunctions or damages caused by modifications, alterations or repairs carried out by any individual or company not authorized by BARCELONA THREE DIMENSIONAL PRINTERS, S.L., being excluded from this assumption the replacements of consumables.

5 Damages caused by unusual failures in the electrical network.

6 Damage caused by abuse, misuse, accident or negligence when using the Product.

7 Effects derived from the Product's exposure to

floods, fire, humidity, spillage of food or chemical compounds, corrosion, oxidation, extreme atmospheric conditions or any other agent external to the Product.

8 Damages derived from the use of Software other than that recommended by BCN3D Technologies.

9 Damages directly caused by the use of incompatible, defective or unsuitable third-party materials.

10 The components considered as Consumables, listed in the attached document.

11 Any product in which the serial number is not visible

Any unauthorized modification, reverse engineering, adaptation or integration of the Product into non-approved systems shall automatically void the applicable warranty.

Limitations and liability exemptions

This Warranty is the sole and exclusive Warranty of BARCELONA THREE DIMENSIONAL PRINTERS, S.L. and the sole and exclusive responsibility of BARCELONA THREE DIMENSIONAL PRINTERS, S.L. for the defects present in its Products. Therefore, this Warranty replaces any other guarantee issued by BARCELONA THREE DIMENSIONAL PRINTERS, S.L., whether oral or written in any method.

However, this Warranty does not limit either the consumer's rights, specified in current legislation, or the rights against the seller, also set out in the legislation.

BARCELONA THREE DIMENSIONAL PRINTERS, S.L. is not responsible in any case for the loss of business, loss of contracts, loss of profits, loss of savings, increase of costs or expenses for the use of its Products. In the same way, BARCELONA THREE DIMENSIONAL PRINTERS, S.L. rejects the responsibility of any indirect, accidental or collateral damage caused by the use of its Products.

In no event shall BCN3D total aggregate liability exceed the purchase price actually paid for the affected Product.

BCN3D does not guarantee uninterrupted availability of cloud services, remote connectivity services, firmware updates or third-party network infrastructure.

The Products are industrial manufacturing tools and are not designed, certified or authorized for use in life-support systems, medical implants, aviation safety systems, nuclear facilities, military critical systems or hazardous environments where product failure may result in death, personal injury or severe property damage.

Warranty coverage is conditioned upon the customer performing reasonable maintenance operations as described in the User Manual and technical documentation.

This Warranty shall be governed by Spanish law. Any dispute arising from or related to this Warranty shall be submitted to the courts of Barcelona, Spain, unless mandatory consumer regulations establish otherwise.

BCN3D does not guarantee the suitability, structural integrity, dimensional accuracy or regulatory compliance of parts manufactured using the Products. The customer is solely responsible for validating and certifying the final application, use and performance of printed parts.

BCN3D shall not be liable for production stoppages, manufacturing delays, loss of productivity or operational downtime resulting from Product malfunction, maintenance operations or technical incidents.

BCN3D reserves the right to modify hardware, firmware, software, technical specifications or Product features without prior notice and without obligation to update previously sold Products.

BCN3D shall not be liable for any delay or failure resulting from causes beyond its reasonable control, including but not limited to force majeure events, supply chain disruptions, transportation incidents, labor disputes, pandemics, cyberattacks or governmental actions.

The customer shall comply with all applicable export control, sanctions and international trade regulations related to the use, transfer or resale of the Products.

Software Limitations

All software, firmware, interfaces, designs, technical documentation and intellectual property rights related to the Products remain the exclusive property of BCN3D or its licensors. No ownership or intellectual property rights are transferred to the customer except for the limited right to use the Product according to its intended purpose.

The customer is responsible for maintaining appropriate cybersecurity measures, network protection and access controls when connecting the Product to internal or external networks.

Cloud services, remote connectivity functionalities, firmware updates, integrations and digital features are provided on an “as available” and “as technically feasible” basis.

BCN3D does not guarantee uninterrupted or error-free operation of cloud services, remote access functionalities or third-party network infrastructures.

Certain functionalities may evolve, be modified, discontinued or replaced over time without obligation to maintain compatibility with previous software versions indefinitely.

Specifications

PRINTER PROPERTIES	Omega I60
3D Printing Technology	Fused Filament Fabrication (FFF)
Architecture	Independent Dual EXtruder (IDEX)
Printing volume	450mm x 300mm x 450mm
Build chamber	Active Heated Chamber up to 70 °C (158 °F) Fully enclosed Safety Pause
Air filtering	Category H13 HEPA filter, Active Carbon filter
Number of extruders	2
Warranty	1 year worldwide
Extruder system	Direct drive bondtech LGX Pro extruders Quick-swap Hotend Tips 1.75mm Filaments
Printing modes	Single mode, Dual mode, Support mode, Duplication mode, Mirror mode
Automatic Calibration System	Main features: Accurate Z homing Quick assisted bed leveling Automatic XYZ offset extruder calibration Automatic Mesh Mapping
Electronics	Single Board Computer: Toradex ARM Compute Module Motion Board: BCN3D Electronics with integrated stepper drivers 32 bit ATSAME51A
Firmware	BCN3D Embedded Linux distribution BCN3D Omega - Marlin 2.1.x
Heated bed	Silicone thermal pad Up to 120°C (248 °F) Flexible Printing Surface
Screen	7" IPS full color capacitive touchscreen
Supported languages	English
Supported files	Supported by the printed: .gcode Supported by Stratos: .3MF, .STL, .OBJ
Operating sound	65 dB (maximum)
Tip/Nozzle diameter	Omega Hotend Tip 0.4 HR (0.4mm tip size) (Included) Omega Hotend Tip 0.6 HR (0.6mm tip size) (Sold separately)

Connectivity	Offline printing: USB Online printing: WiFi (Dual Band 2.4/5 GHz 2x2 Wi-Fi 5 (802.11ac)) Ethernet (through BCN3D Cloud)
Materials Operation System (MOS)	70 °C (158 °F) max temperature Average relative humidity <10%
Camera	Yes (visualization via screen)
MATERIALS	
Filament diameter	1.75 ± 0.05 mm
Compatible materials	BCN3D Filaments (for Omega) Open Filament Network (for Omega) Custom Materials (with free license activation) ¹
Open filament system	Yes (with free license activation)
PHYSICAL PROPERTIES	
Overall dimensions	987 x 600 x 1927 mm (38.86 x 23.62 x 75.87 in)
Weight	240 kg (530 lbs)
Shipping box dimensions	1180 x 725 x 2100 mm (46.5 x 28.54 x 82.7 in)
Shipping weight	260 kg (573.2 lbs)
Shipping method	Custom pallet 1180 (W) x 720 (D) mm (46.46 (W) x 28.35 (D) in)
Minimum working area	For printer operation: A minimum clearance of 20 cm (8") is required on all sides of the printer, except for the front, where a clearance of 80cm (32") is necessary to operate the printer. For technical service: A minimum clearance of 80 cm (32 in) is required on all sides of the printer for accessing the front, right, and rear panels, except for the left side, where a 20 cm (8 in) clearance is sufficient.
Air/ventilation requirements	No additional requirements
PRINTING PROPERTIES	
Recommended profiles	Built-in print profiles in slicer software
Accuracy ²	XY part accuracy +/- .200 mm (.008 in), or +/- .002 mm/mm (.002in/in), whichever is greater. Z part accuracy +/- 0.200 mm (+/- 0.008 in.) or +/- 0.002 mm/mm (+/-0.002 in./in.), +/- 1 layer height.

Layer height	50 µm minimum, 300 µm maximum
Operating temperature	Temperature: 18 - 30 °C (64.4 - 86 °F), Humidity: 30 - 70% RH
Extruder maximum temperature	300 °C (572 °F)
Heated bed maximum temperature	120 °C (248 °F)
Build chamber maximum temperature	70 °C (158 °F)
MOS ³ maximum temperature	70 °C (158 °F)
ELECTRIC PROPERTIES	
Input	AC 200-240V, AC 10,25-8,5A, 50-60Hz
AC Power Socket	USA: NEMA 6-20, EU: Schuko, UK: BS1363, Australia: AS3112
Maximum power consumption	2050W
UPS Topology	Online 1kVA Battery specifications: 3 batteries, each 36VDCx7Ah
SOFTWARE	
File preparation software	BCN3D Stratos for slicing and BCN3D Cloud for printer management
Operating Systems	Windows 10 or higher, 64-bit, Mac OSX 11 Big Sur or higher, 64-bit, Linux, 64-bit
Connectivity	Online printing: WiFi or Ethernet (through BCN3D Cloud) Offline printing: USB
Supported browsers	Google Chrome, Mozilla Firefox, Safari

¹ The Omega I60 is an open material platform that offers customers the flexibility to use custom materials and create their own printing profiles at no extra cost. An Omega Open Filament License (OOFL) is required for this purpose.

For more information: <https://3d.bcn3d.com/bcn3d-omega-i60-omega-open-filament-license>

² Test conditions: 0.4mm hotend tip , 0.15 layer height , Material: Omega Proto. The accuracy is dependent on geometry and the achievable accuracy specification is derived from statistical data at 95% dimensional yield.

³MOS (Material Operation System)

All specifications are approximate and subject to change without notice.

EN-DS-v9

Diagrams

Printer Omega I60

- | | |
|--|------------------------------------|
| 1. Bowden tubes | 15. UPS control screen |
| 2. Print heads (Incl. Extruder motor and Hotend) | 16. Material Operation System door |
| 3. Purge bucket | 17. Heated chamber door |
| 4. Flexible printing surface | 18. Electronics panel |
| 5. Touchscreen | 19. Electronics vent |
| 6. H13 HEPA filter, Active Carbon filter | 20. Camera |
| 7. Code scanner | 21. Andon light system |
| 8. USB port | 22. WiFi antenna |
| 9. Filament loading ports (A B C D) | 23. Power socket |
| 10. Emergency Stop button | 24. Power On/Off switch |
| 11. Reset button | 25. Ethernet cable port |
| 12. Heated chamber and MOS door opening button | 26. Wheel break |
| 13. MOS air duct vent | 27. Leveling feet |
| 14. Spool bays | |

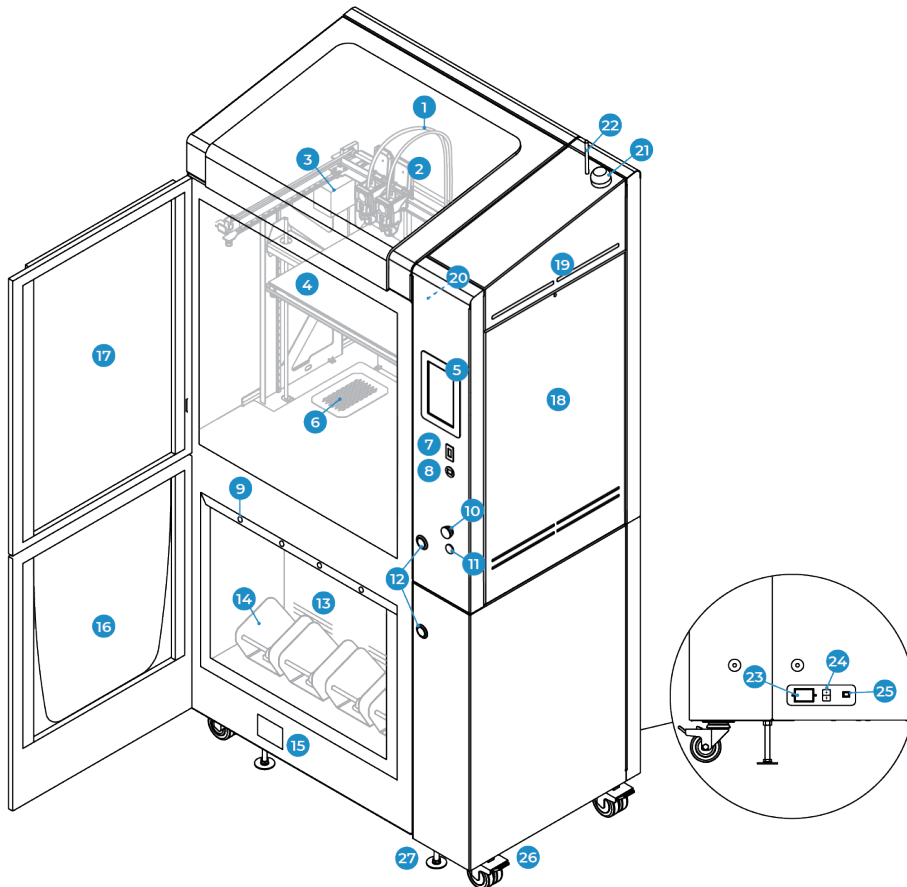

Print heads

- 1. Left cover
- 2. Screws that fix Left cover
- 3. Left layer fan
- 4. Upper cover
- 5. Bowden entry
- 6. Front cover
- 7. Print head LED
- 8. Hotend cooler fan
- 12. Extruder motor
- 13. Extruder
- 14. Piezo sensor
- 15. Heater block
- 21. Extruder lever
- 22. Extruder bowden entry
- 23. LED support
- 24. Hotend tip *HR 0.4mm included

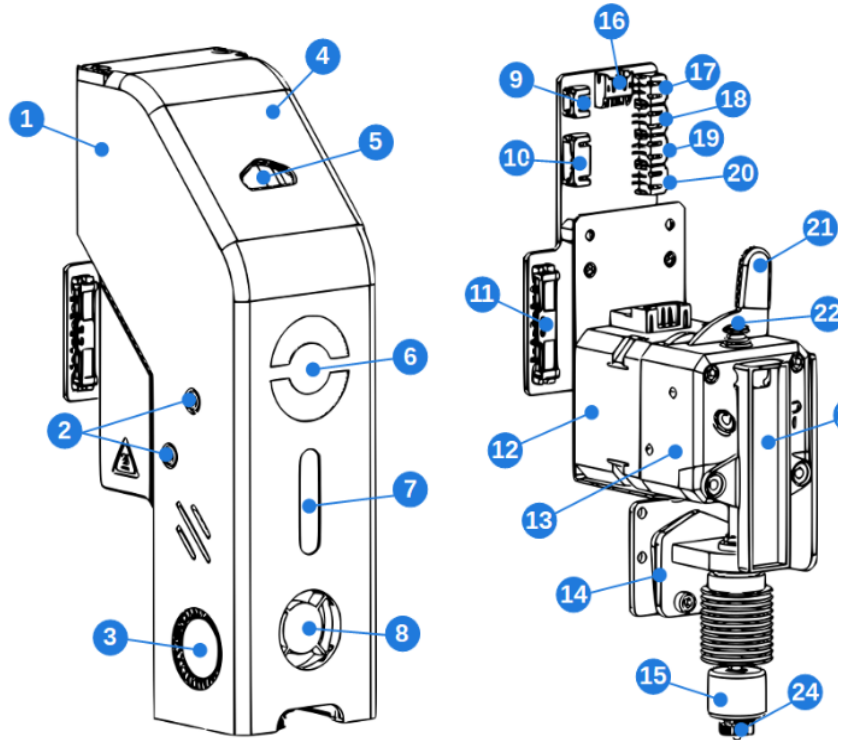

Extruder board connections

- 9. Print head LED
- 10. Extruder motor
- 11. Flat cable
- 16. Heater block
- 17. Piezo sensor
- 18. Right layer fan
- 19. Left layer fan
- 20. Hotend cooler fan

Printing platform

- 1. Alignment pins
- 2. Flexible printing surface
- 3. XY calibration camera
- 4. Thumbscrews *Build plate adjustment

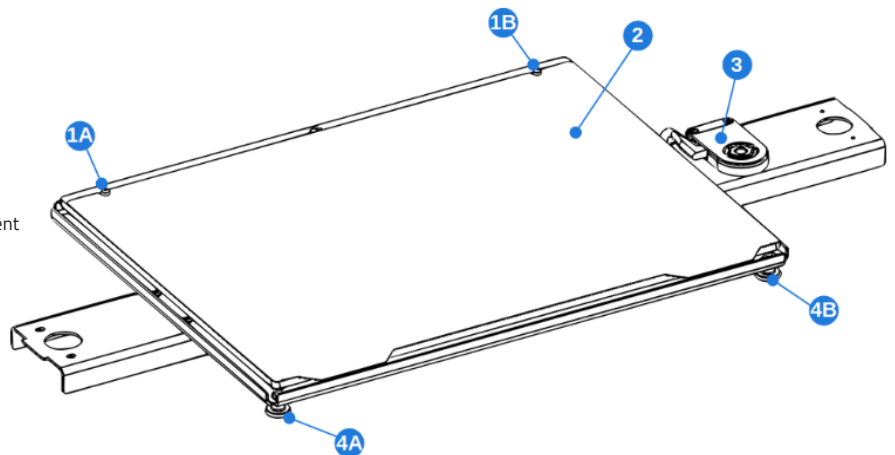

Safety and compliance

General information

To avoid potential residual risks the user should read and understand the following safety measures (you are strongly advised to read this before using the machine).

To highlight the areas where extra care should be taken, safety alert stickers have been affixed to the relevant parts of the machine to warn the user of potential hazards.

BARCELONA THREE DIMENSIONAL PRINTERS, S.L. ARE EXEMPT FROM ANY LIABILITY IF THE USER DOES NOT FOLLOW THE INSTRUCTIONS FOR USE.

Hazards

Intended use

BCN3D Omega I60 has been designed for use in the industrial environment. It is intended for the production of printed parts using approved plastic filaments. The equipment generates printed parts from models created using specific slicing software.

This device is not a toy. It should not be used by minors under 16 without the supervision of an adult.

The spatula can be a dangerous tool that may cause injuries. Use it only to remove plastic residue after calibration assistant or a printing job.

Remove flexible printing surface

To remove the print, you should wait until the printing surface has cooled off to temps below 50°C. Only then you should remove it from the printer and then proceed to remove the piece from the printing surface by bending the metal sheet slightly in both directions

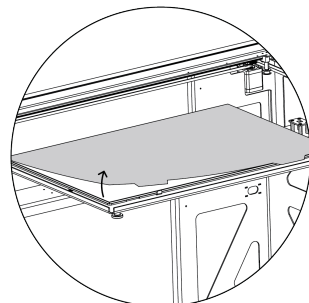

Explanation of safety symbols



DANGER

Indicates a danger with a high level of risk. If not avoided, it could result in death or serious injury.



WARNING

Indicates a danger with a moderate level of risk. If not avoided, it could result in death or serious injury.



CAUTION

Indicates a danger with a low level of risk. If not avoided, it could cause minor or moderate injuries.



NOTICE

Important information calling for special attention. Damage to the machine will occur if precautions are not taken.

The following stickers have been affixed to the printer to warn users about the hazardous areas of the machine, and actions which are not recommended as they will stop the machine from working properly.

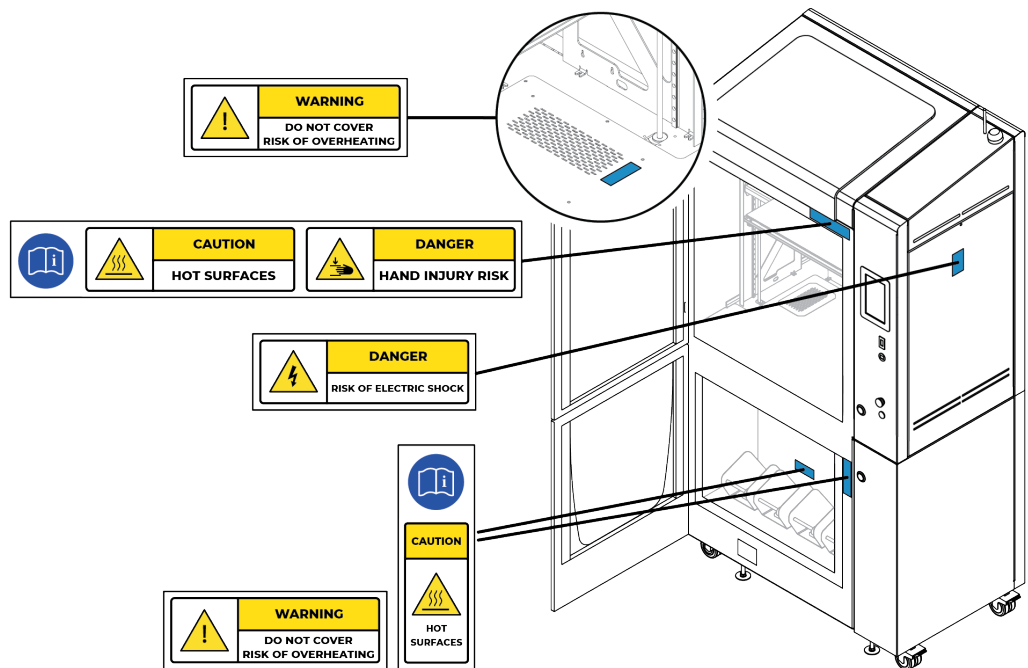

**CAUTION HOT SURFACES**

Do not touch the hotbed or print heads while the printer is working. After any heating procedure, this parts will remain hot for 15 minutes. Avoid touching these components before they have completely cooled down.

Pay close attention to the temperature indications displayed on the screen.

There is a potential risk of burns: the hotend can reach temperatures of up to 300°C, while the silicone hotbed can reach temperatures of 300°C. Do not touch any of these parts with uncovered hands.

**DANGER HAND INJURY RISK**

Do not put any object or part of the body between the mobile parts of the printer, when it is moving or can start moving.

Specifically the force of the build plate is enough to cause damage.

Always unplug the printer before performing maintenance or modifications.

**DANGER RISK OF ELECTRIC SHOCK**

As with any other appliance, do not touch the terminals of the mains, the switch, or the power source. There is a risk of electrocution. Connect the machine to an electrical outlet according to the current legislation. Do not connect or disconnect any internal components or electrical connections in the printer while it is connected to a power source. In the event of an emergency, stop the machine immediately by pressing the switch, and disconnect the power source.

**WARNING DO NOT COVER**

Do not cover the hot air intake or exhaust vent of the heated chamber or the Material Operation System (MOS).

There is a risk of fire if, during operation, the air vents are covered or come into contact with flammable materials.

Door Locks

The printer is equipped with opening and closing sensors on both the door of the Printing Chamber and the Material Operation System (MOS).

If the door of the heating chamber is opened during a print, the machine will immediately pause, and printing cannot be resumed until the door is closed. If during a drying cycle, the MOS door is left open, exceeding 10% humidity, a warning message will be displayed to restart the drying cycle.

Emergency Stop

Pressing the emergency stop button immediately cuts off the power supply to the system. The emergency stop button should only be used in case of extreme emergency, not as the standard system for turning the machine off.

As part of the maintenance tasks, the proper operation of the emergency button must be checked monthly. See the Maintenance section for more information.

To restore power after an emergency stop, follow these steps:

1. Unlock the emergency stop button by turning it clockwise. (10)
2. Press the reset button. (11)

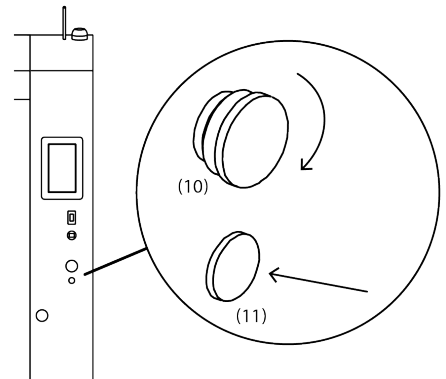

* If you have completely turned off the printer using the rear power on/off switch, please note that you must wait for 15 seconds before being able to engage the emergency button. This is the normal behavior of the printer.

*To completely turn off the printer, switch off the switch located at the back of the printer, next to the power cable. Depending on the UPS battery level, the printer may remain on for a few minutes.

Andon Light

The andon light indicates the status of the Omega I60.

COLOR	MODE	MEANING
Green	Static	The entire system is functioning correctly. No user intervention required (Ready to print)
	Blinking	The entire system is functioning correctly. No user intervention required (Printing, Firmware update, Routine in progress)
Yellow	Static	Printing or routine has ended without issue. User intervention required (Finished print job, Routine finished)
	Blinking	Printing or routine interrupted. User intervention required (Run out of filament, Safety pause due to door open, print launched but does not match setup)
Red	Static	Printing or routine failed. User intervention required (Error on screen, E-stop is pressed)

Proper area to install the printer

To define the necessary free area for installing the printer, we can differentiate between two situations: the space required for normal printer use and that required for performing maintenance or technical service.

For printer operation

A minimum clearance of 20 cm (8") is required on all sides of the printer, except for the front, where a clearance of 80 cm (32") is necessary to operate the printer.

For technical service

A minimum clearance of 80 cm (32 in) is required on all sides of the printer for accessing the front, right, and rear panels, except for the left side, where a 20 cm (8 in) clearance is sufficient.

Never cover the printer while it is working.

Install the printer in a location away from other machines or tools that may produce dust or sparks, such as woodworking or metalworking equipment.

Use the machine in a controlled temperature and humidity environment: Temperature 18-30°C (64-86°F) and Relative Humidity 30-70%. Exposing the printer or the material to high levels of humidity can cause equipment malfunction and printing failures.

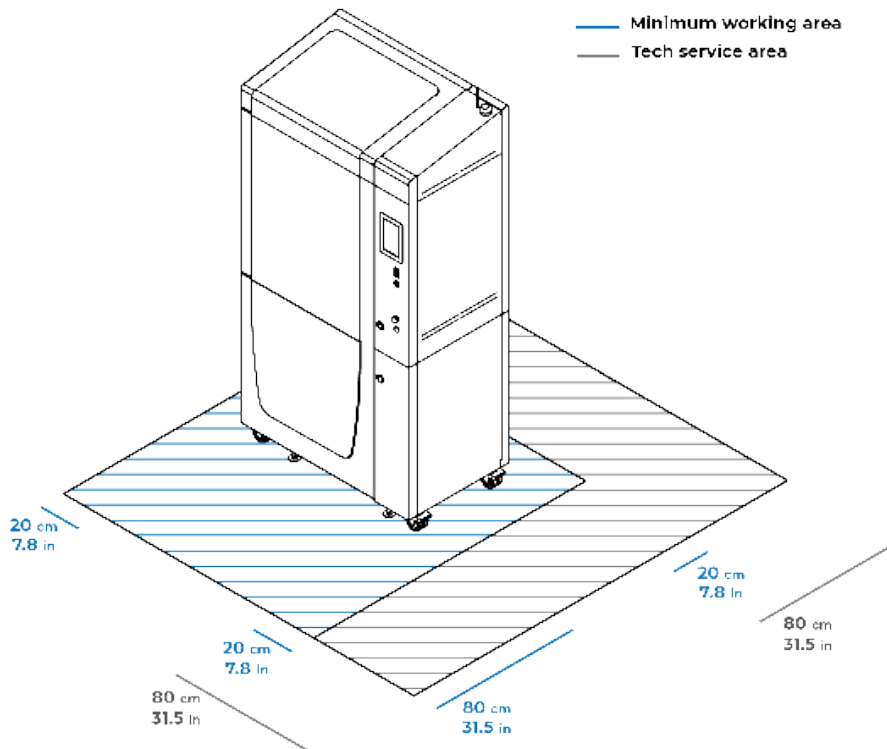

Moving the machine

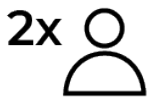
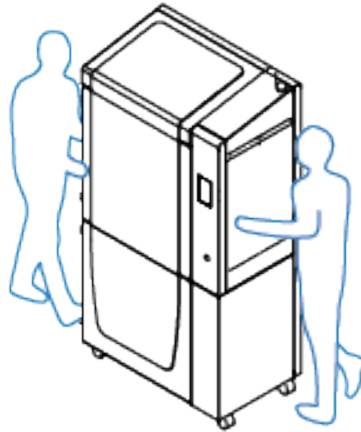

The machine is heavy, do not move the printer without the help of a second person. Two people are necessary to safely transport the printer. During the unpacking process, never lower the printer from the pallet without the help of a second person, the printer could overturn and cause serious damage to you and the equipment.

To ensure safe movement of the machine, follow the steps described below:

- Make sure the printer is not printing or performing any routines. The printheads should be stopped in the home position.
- Turn off the rear switch of the printer and disconnect the power cable.
- Disconnect the Ethernet connection cable if necessary.
- Take into account the height of the WiFi antenna when passing through door frames; lower the antenna to avoid collisions.
- Confirm that the build plate assembly is correctly installed with the securing clips closed.
- Raise the leveling feet until all four wheels touch the floor, release the wheel brake. If going up ramps, it's necessary to raise the feet at least 4 cm above the floor level to avoid collisions.

Installation

What is in the box?

Printer box:

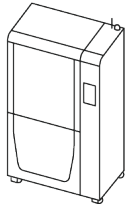

BCN3D Omega I60

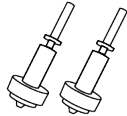

2x Hotend tip 0.4 HR
*Installed

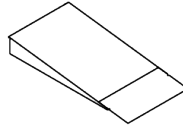

Ramp

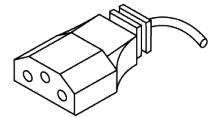

Power cable

Starter box *inside the printer



Omega Proto spool

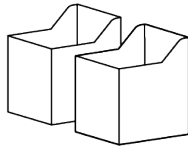

2x Purge buckets

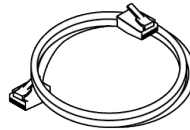

Ethernet cable

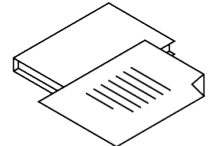

2x Warranty and conformity

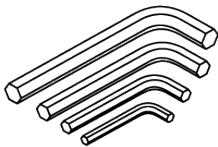

Allen keys



Spatula

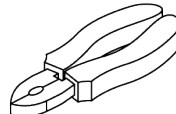

Cutting pliers

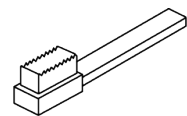

Metal brush

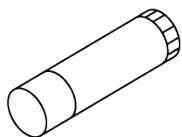

Magigoo glue stick

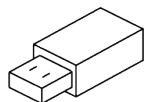

USB pendrive

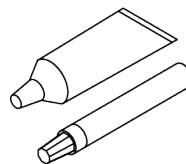

Lubrication kit

Unboxing

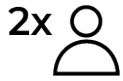

The printer is heavy and therefore this step needs to be performed by two people.



Retain packaging, and pallet for warranty service.

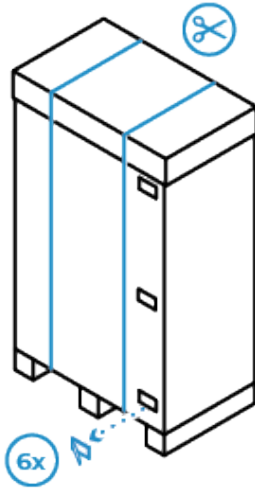

1. Cut the two outer straps of the box. Then remove all the closing clips you will find both on the front and the back.

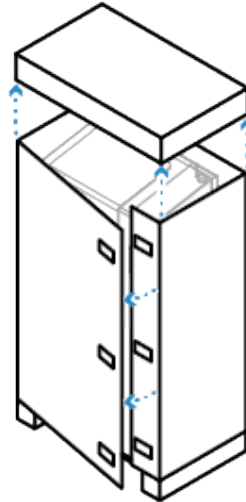

2. First, remove the lid and then take off the side panels of the box.

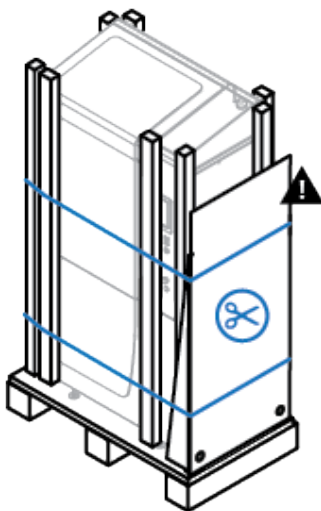

3. Hold the ramp with one hand and use the other to cut the two straps holding it. Be careful, the ramp is heavy and can cause damage if it falls.

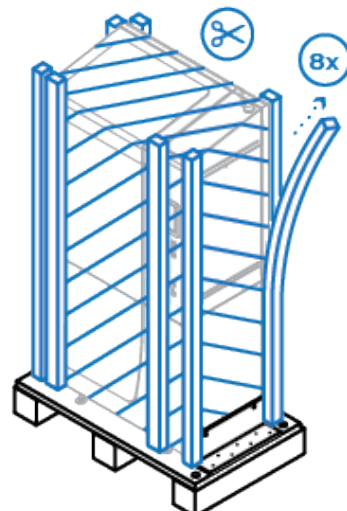

4. Remove the foams, the ramp cardboard protection, and the protective film from the printer.

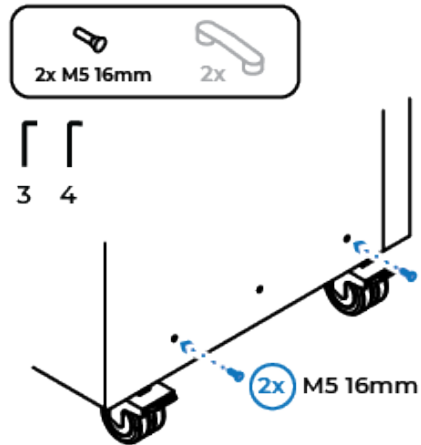
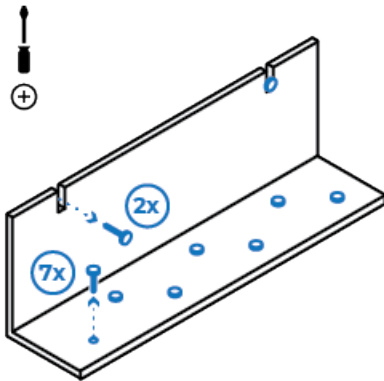

5. Behind the ramp, you will find a metal plate that secures the printer. Remove it by taking out the 2 screws holding the printer and the 7 screws attached to the pallet.

6. Once you have removed the metal plate, take the two M5 16mm screws included in the zip bag and install them into the holes on the side of the printer.

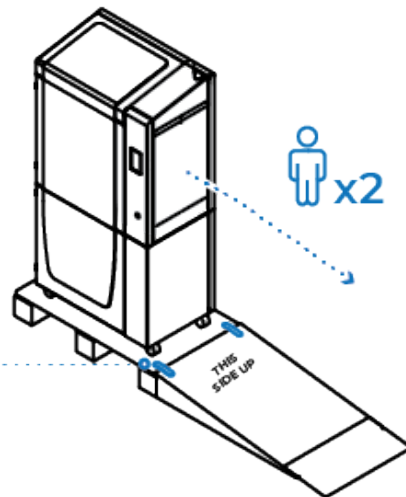
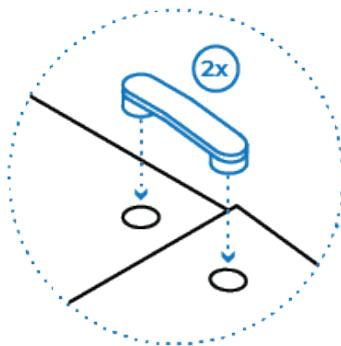
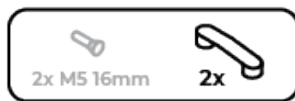

7. Before unloading the printer, install the ramp using the clips included in the zip bag.



Two people are required for this step. When unloading the printer, take special care to lower it centered on the ramp. If one wheel comes off the ramp, it could cause the entire printer to overturn and cause serious damage to you or the equipment.

Basic setup

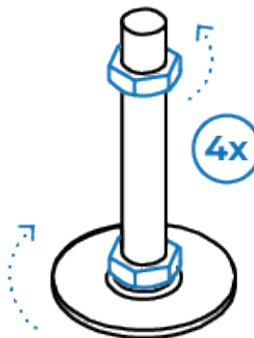
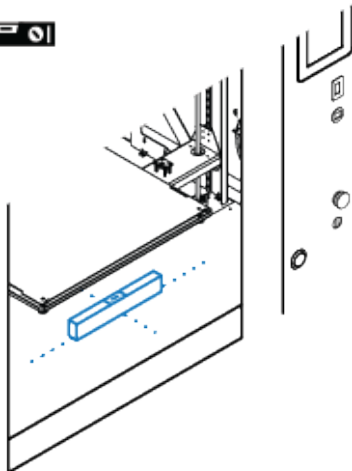

8. Once the printer is in its final position, lower all the feet (27), ensuring that the printer is perfectly leveled. Place the bubble level inside the heated chamber to confirm that it is correctly leveled in both axes. Then, tighten the upper nut of all 4 feet upwards.

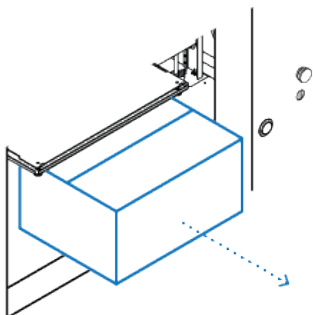

9. Remove the Starter Box. Inside you will find the instructions for setting up the printer.

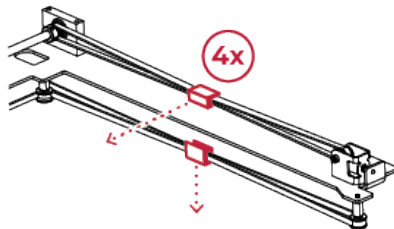

10. Remove the 4x belt clips that secures the print heads.

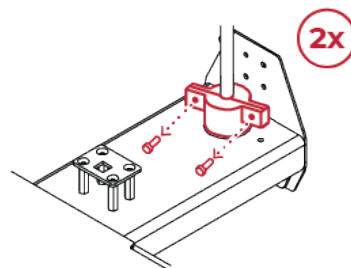

11. Remove the 2x clamps holding both Z-axis spindles, left and right side.

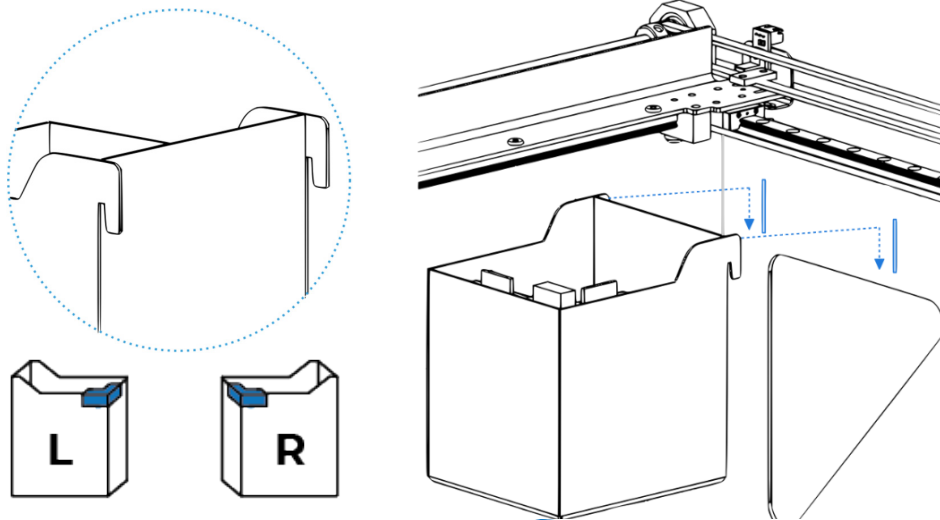

- Place the purge buckets in their top-corner position inside the printer (3). Align the two tabs with the mounting holes and slide the purge bucket downward. Confirm that both the left and right print heads pass correctly through the cleaning brushes by manually moving them.

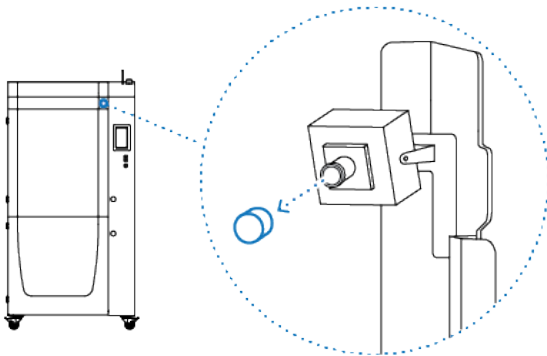

- Remember to remove the cover that protects the camera lens so you can monitor the print from the BCN3D Cloud (20).

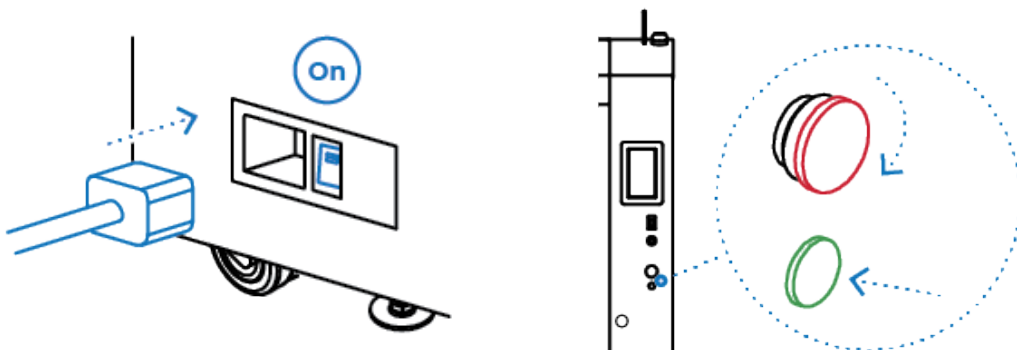

- Connect the power cable to the back of the printer (23), turn on the printer.
- Finally, unlock the emergency button (10) by turning it clockwise and then press the reset button (11). The printer may take 15 seconds to set up the emergency button for the first time.

Connecting the printer

The BCN3D Omega I60 can be used online or offline. However connecting the printer to the network is needed in order to register it and to use the BCN3D Cloud functionality. Furthermore, having the printer connected makes it easier for providing assistance, as it facilitates diagnostic work and the sending of log records.



If you have the option, we recommend using the printer with an Ethernet connection as it is more stable than Wifi.

Ethernet

- Take the ethernet cable out from the Starter box.
- Connect the ethernet cable to the ethernet port at the back of the printer (25).
- Connect the other end of the cable to a network source.
- No extra step is needed, the printer will automatically connect to the network.

WiFi

- The Omega I60 comes with a built-in antenna (22). By default, the antenna is lowered during shipping.
- To achieve the maximum range for detecting networks, you just need to raise it.
- To select the WiFi network, go to the Settings/ Network Connection/ Wireless Settings. There, you can select your network and enter the password.
- If the printer has connected successfully, a blue checkmark symbol will appear next to your network.

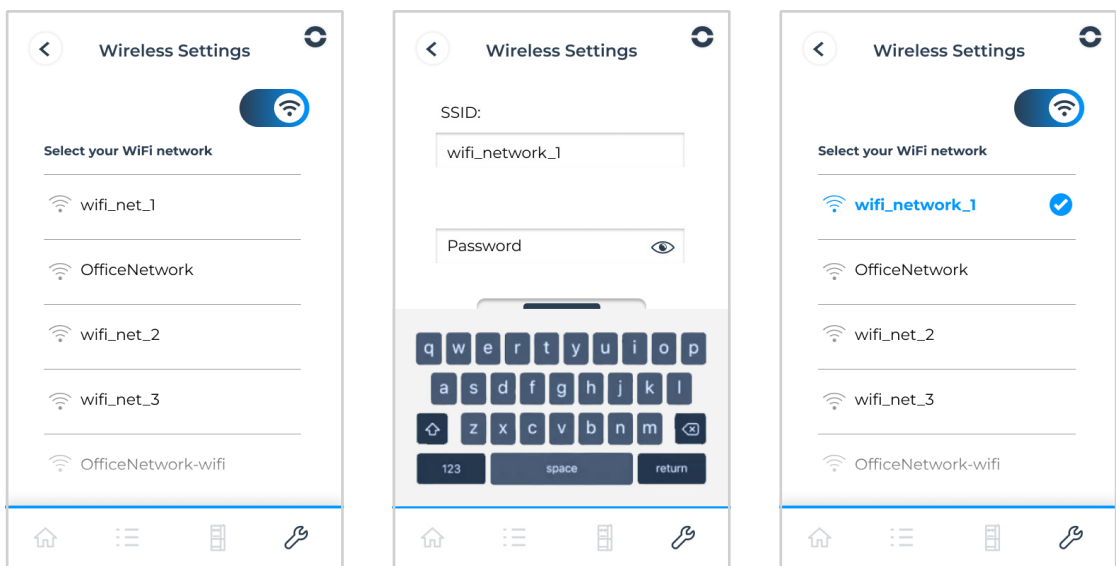

Register the printer



This process automatically activates the printer. Activating the product is a mandatory step for warranty and support purposes.

Registering the printer allows the user to connect and use BCN3D Cloud functionalities. To perform this operation, the printer must have a working internet connection.

Registration process *(Settings/General/Registerprinter)*

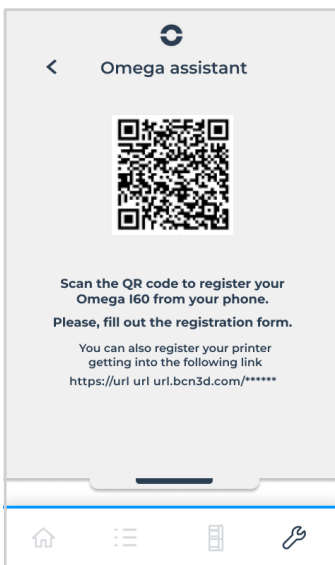
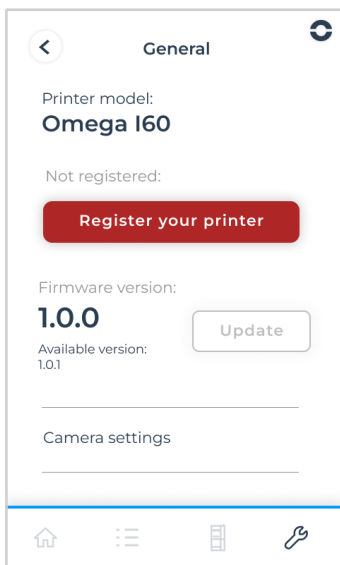

- Once the printer is connected, go to Settings/General screen, then click on the "Register your printer" button.
- The Omega Assistant will open a popup with a unique access QR code for your printer. Scan the QR code with your smartphone or access the URL displayed at the bottom of the screen.



BCN3D
CLOUD

To register the printer, you must assign it to a BCN3D Cloud account. This does not imply that your printer will remain permanently connected to the internet; you can work offline later if you prefer.

- If you don't have a BCN3D Cloud account, follow step A to receive instructions on how to create an account.
- If you already have a BCN3D Cloud account, you can proceed directly to step B.

Step A - New User

- If you don't have a BCN3D Cloud account, click on the link "You do not have an account? **Start here.**"
- This will redirect you to the account registration screen. Enter your name, email, and password.
- You will receive an email to activate the account. Once your account is created and verified, you can proceed to step B.

You do not have an account? [Start here](#)



Create an account

Name

E-mail:

Password

Send me emails from time to time about news and advice on 3D Printing.

Get started for FREE

By clicking this button you confirm that you agree with our [Privacy Policy](#) and [Conditions of Use](#)

[Do you already have an account? To access](#)

Step B - Existing User

- Access the registration form again by scanning the QR code or entering the URL that appears on the screen.
- Enter your BCN3D Cloud account details, email address and password.
- Fill out the form regarding your Omega I60 printer and click on "Register."
- On the printer screen, you will see a message confirming that the printer has been successfully registered.

Omega I60

Serial number:

When did you start using this printer?:

This will be used for:

Application:

Industry:

Country:

Phone number:

Register

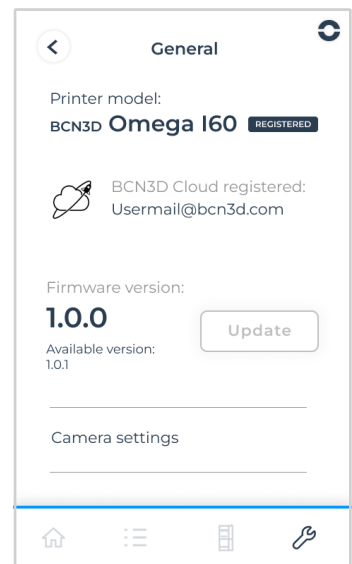
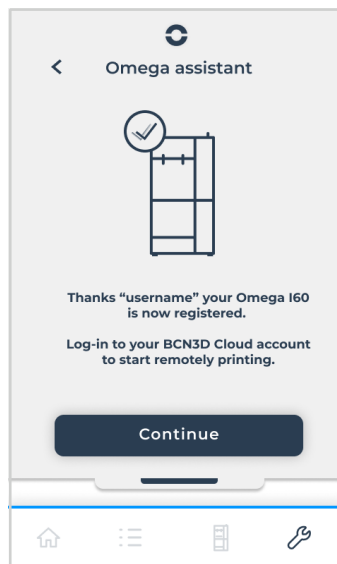

Example URL: https://cloud.bcn3d.com/register/****

Offline mode

If you are unable to connect your printer to the internet for registration, please contact the BCN3D support team to activate your product through the Technical Service Mode.

BCN3D Omega support: omega-assistance@bcn3d.com

USB drive

- If you want to use the printer offline, you can print your files using the USB drive included in the Starter Box.
- Connect the USB drive to the USB port (8), then go to the Print Files/ USB screen to select the file you want to print.

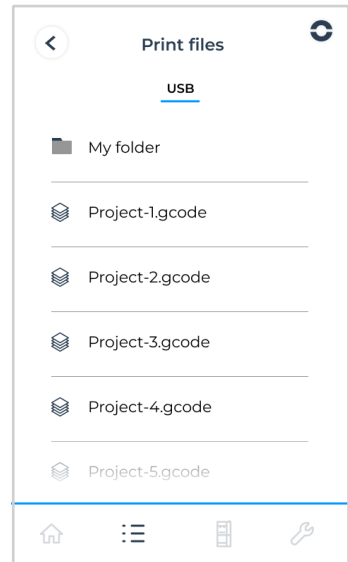

User interface

Overview

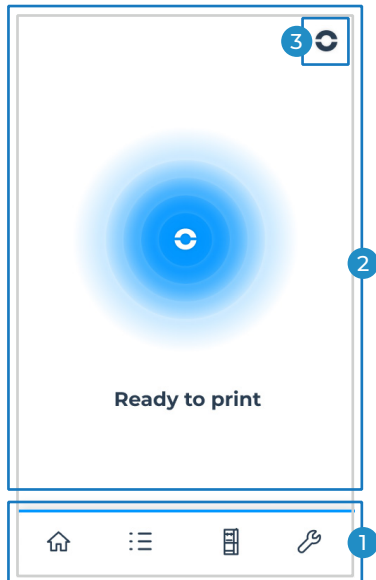





The printer's touchscreen is located on the front right side. The screen is designed to reduce reflections, allowing for clear visibility when standing directly in front of it. If you view the screen from any other angle, you may not see the information clearly.

The screen is divided into 3 main areas.

1. Navigation menu
2. Display area
3. Omega Assistant.

Navigation menu

The navigation bar allows you to move quickly between the different sections of the interface:

	Home / Printing
	Print files
	Printer Setup
	Settings

Blue background button, marks the section of the menu you are currently in.

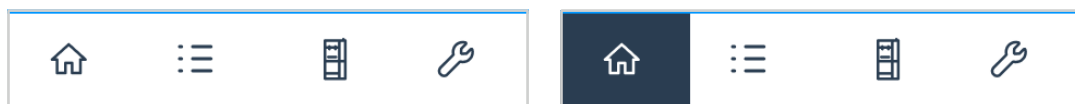

For security reasons, the horizontal menu may remain disabled while certain routines are being carried out.



Printing screen

The printing screen displays all the necessary information during the part fabrication process.

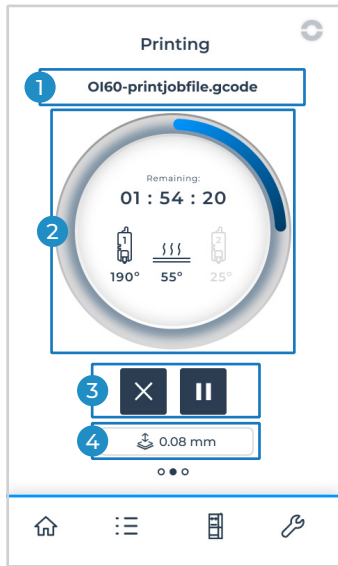

We can differentiate four different zones:

1. Print job name
It indicates the name of the file currently being printed.
2. Build progress and temperatures information
Indicates the remaining print time and the progress circle. Additionally, it shows which print heads are being used during the print and the temperature of the bed and the print heads.
During the start and end of printing, information regarding the routine being executed is also displayed. Whether it's nozzle cleaning, mesh mapping calibration, or preheating.
3. Cancel/Pause buttons
It allows pausing and resuming a print, or canceling it altogether.
4. Changes in printing parameters
If a change is applied to the parameters during the printing process, or if a change is made to the Build plate offset value, these changes will be displayed at the bottom of the screen.



Print files

In the Print Files menu, the files from the USB flash drive are displayed when it is connected. It allows selecting the file to print as well as viewing a brief summary of the parameters with which it has been laminated.

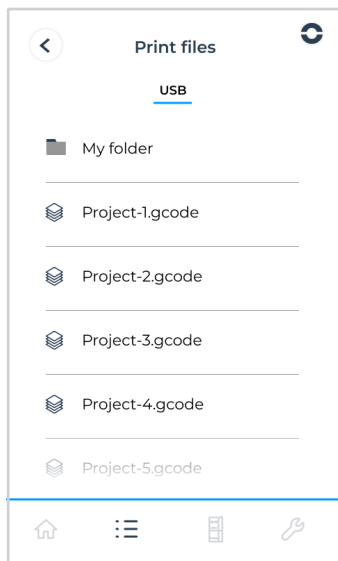

1. Project name
2. Printing mode and print heads that will be used.
3. Hotend tip size
4. Printing material
5. Print time
6. Layer height



Printer setup

From this menu, you can see in detail how your printer is configured. You can control and customize each of the elements according to the needs of the project to be printed.

The dropdown arrow next to each component will give you quick access to some actions and routines or will display specific information on how that component is configured.

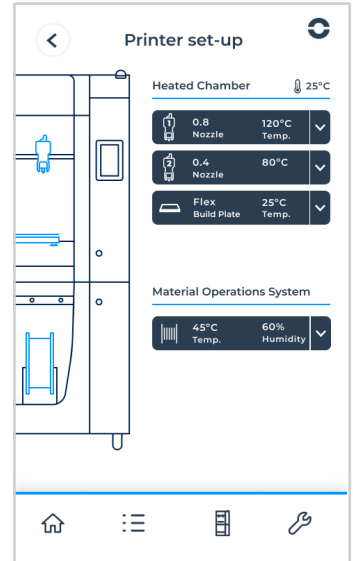
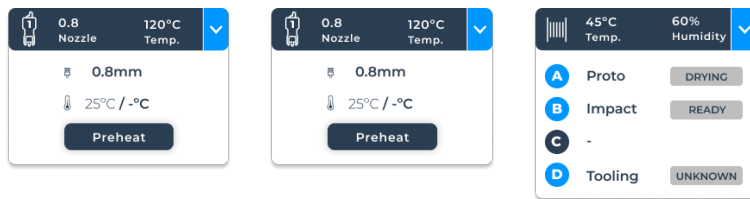

Each of the components that can be configured in your Omega I60 has a specific submenu from which you can adjust the specific settings of that component.

Print heads

From this menu, you can switch between the two print heads and execute the following routines:

- Preheat (*Setup/Hotend/Preheat*)
By pressing the preheat button, the nozzle will start to heat up to the predefined temperature for the loaded material. If you load a Custom material, the temperature you set will be used for preheating.
*If there is no material loaded, the default preheat temperature will be 215°C.

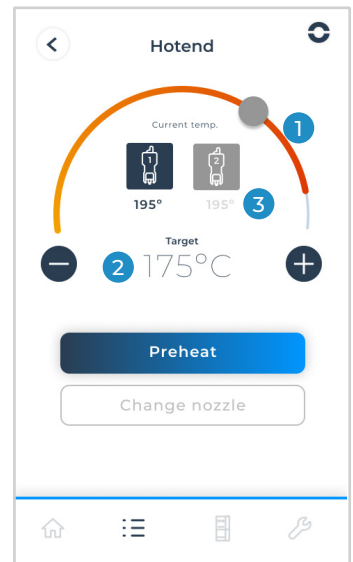

You can modify the target temperature by moving the gray dot on the progress bar, dragging the dial left or right, or by pressing the + - buttons.

1. Progress bar and dial for adjusting target temperature
2. Target temperature
3. Current temperature at which each of the nozzles is operating





- **Change hotend tip** (*Setup/Hotend/Changehotendtip*)
Changing the hotend tip is straightforward, and the assistant will guide you through the entire process.

Omega I60 is compatible with nozzles of different sizes. The following table indicates which one to use in each case.

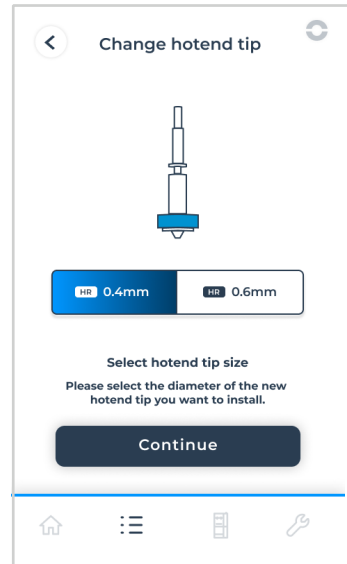
 0.4mm	<p>Hardened 0.4mm hotend tip Compatible with Omega Proto and Resistant Nylon. *included with the printer</p>
 0.6mm	<p>Hardened 0.6mm hotend tip Compatible with Omega Tooling CF and suitable for fiber filaments.</p>



 It's crucial to always use the assistant when changing the hotend tip so the printer can ensure that the material is unloaded and that the nozzle has cooled to a safe handling temperature.

 Printing fiber-based filaments with a 0.4mm hotend tip can lead to clogging issues.

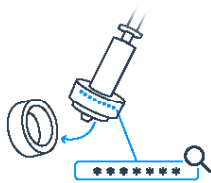

During the hotend tip change process, you will need to enter the 7-digit serial number of the nozzle you are installing. This allows you to better track the nozzle's usage, allocate certain nozzles for use with specific materials only, and thereby extend the component's lifespan.

You can find the hotend tip's serial number both on the box it comes in and engraved on the nozzle itself.

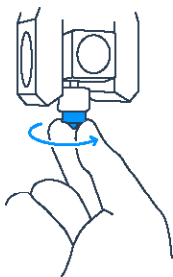

To install the new nozzle, simply screw it in manually, ensuring it is tightly secured all the way in. There's no need for tightening tools

To avoid losing calibration between print heads, it's important that the hotend tip is always properly installed and tightened.

If necessary, perform a Z-axis auto-calibration routine.

Build plate

In the build plate menu, in addition to the preheating option, printing surface calibration and platform movement routines are included.

* The print head calibration menu has been included in the printer settings section as it is a maintenance task that doesn't need to be performed as frequently.

- **Preheat** (*Setup/Buildplate/Preheat*)
The build plate preheat menu works exactly the same as the print heads. The main difference is that the maximum temperature that can be set for preheating is 110°C, and there is no specific target temperature depending on the loaded material. The default preheating temperature is 80°C.

You can adjust the temperature by moving the gray dot on the progress bar, dragging the dial left or right, or by pressing the + - buttons.

1. Progress bar and dial for adjusting target temperature
2. Target temperature
3. Current temperature

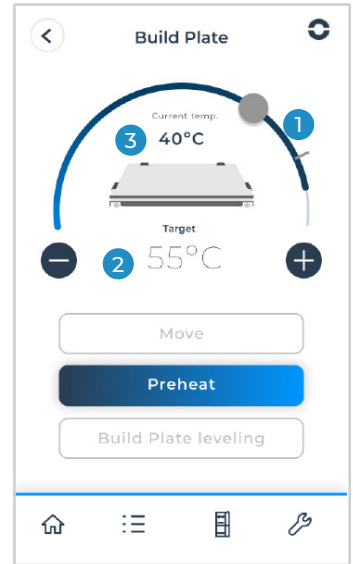

- **Move platform** (*Setup/Buildplate/Moveplatform*)
When accessing the menu, the printer will always perform a homing movement to obtain the zero position of the platform. You may notice that occasionally the arrows are disabled; this is because the platform is at its upper or lower limits, and until a movement in the opposite direction is made, those buttons will remain inactive.

	<p>Up / Down Move arrows The platform only moves while the button is pressed.</p>
	<p>Move to the Lowest / Highest position You only need to press it once, and the platform will start moving to the lowest / highest position.</p>

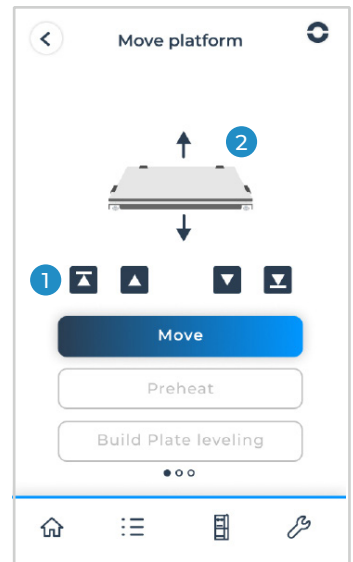

The flashing arrows in the illustration will indicate whether the platform is moving and in which direction.

1. Platform movement buttons
2. Illustration indicating whether the platform is moving

- **Build plate leveling** (*Setup/Buildplate/Buildplateleveling*)
 After transportation or after several prints, it's possible that the build plate becomes unlevel. That's why it's advisable to periodically perform a build plate leveling routine.
 * Refer to the maintenance section for more information.

When initiating the calibration routine, the build plate will heat up to 85°C; this is necessary to recreate printing conditions. While it heats up, the printer will start a cleaning routine of the left nozzle (the nozzle used for measurement tasks). The objective of this cleaning process is to remove any filament blob that may be adhered to the nozzle tip and could affect the measurements.

Once the cleaning is complete, the printer will measure 3 points on the bed and determine the necessary adjustments to correct any deviation. The screen will indicate which of the thumbscrews needs to be adjusted, the rotation direction, and how much the thumbscrew needs to be turned..

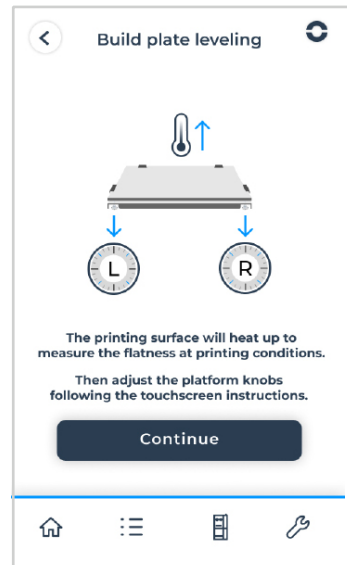

	<p>"L" or "R" indicate which of the two thumbscrews (left or right) should be adjusted.</p>
	<p>The blue "Check" indicates that that thumbscrew is already properly calibrated.</p>
	<p>Example 1: In this case, it is necessary to turn the left thumbscrew counterclockwise 1/4 of a turn.</p>
	<p>Example 2: In this case, you should adjust the right thumbscrew by turning it clockwise 1/2 turn.</p>



It is necessary to repeat the calibration as many times as necessary until the screen shows the success message. The printer will keep heating the print surface throughout the process, so you won't have to wait between measurements.

Material Operation system

From the MOS screen, you can see all the information regarding the loaded materials, the humidity level and temperature at which they are stored.

Additionally, if you start a recovery cycle, you'll be able to see in which drying phase each spool is.

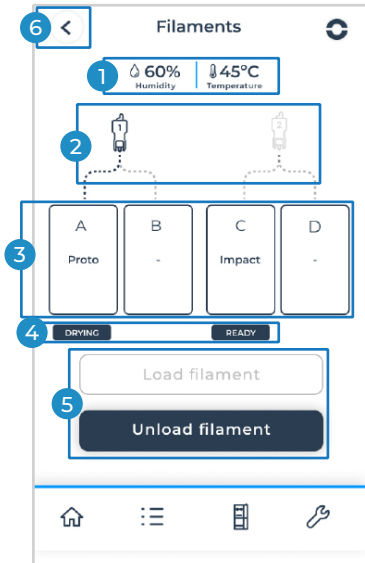

1. Temperature and humidity level information of the MOS.
2. Selected print head.
Ports A and B correspond to print head 1, and ports C and D correspond to print head 2.
3. Loading bays A, B, C, D.
*The printer will only allow loading or using the other bay when the spool is unloaded. As long as there is a loaded material, the Load function will remain disabled.
4. Information about the drying and recovery status of each spool.
5. Material Load and Unload buttons.

Material status icons

	<p>There is no material loaded, and bay A is not selected.</p>
	<p>There is material "Proto" loaded, and bay A is not selected.</p>
	<p>A blue frame highlights bay A. There is material "Proto" loaded, and bay A is selected. If the user initiates an unloading process, it will be performed in the selected bay A.</p>

BCN3D Omega I60 Materials

BCN3D Omega materials have been specially formulated to ensure the best printing performance and repeatability when used with the BCN3D Omega I60 printer.

Omega I60 Materials	Applications and properties	Printing requirements
Proto	Functional prototyping Low load fixtures Alignment jigs Basic workholdings Gauges Location and general assembly fixtures Attractive matt surface quality Easy to print, machine, and finish	Hotend Tip 0.4 HR
Resistant Nylon	Acetal replacement End effectors Non-marring tools Low-speed gears and moving parts Self-lubricating properties	Hotend Tip 0.4 HR
Tooling CF	Exceptional strength Easy to print while boasting a variety of excellent mechanical properties High impact resistance Metal replacement Replacement for high-pressure metal forming tools High temperature jigs and fixtures Workholdings Automotive parts, brackets, covers Jigs and fixtures that need high strength and stiffness	Hotend Tip 0.6 HR
Impact	Highly impact resistant Heat resistant (up to 90°C) Food safe Electrical enclosures Jigs and fixtures End-use mechanical parts	Hotend Tip 0.4 HR
Support		

Omega I60 can work with a wide range of materials, open to third-party filaments.

If you need help setting up a correct print profile, you can consult the Stratos section in the BCN3D Knowledge Base. Additionally, you can refer to the materials of the BCN3D Open Filament Network, the result of continued close collaboration between BCN3D and leading material manufacturers in order to provide our customers with access to the best-performing filament profiles.

BCN3D Open Filament Network

<https://www.bcn3d.com/open-filament-network/>

Preloading filament *(Setup/MOS/Loadfilament)*

Whenever you want to load a spool, it is necessary to do so through the preloading assistant. Don't insert the filament in any loading port unless you have first executed the preloading routine.

To ensure that the material is correctly loaded, follow the steps outlined below:

- To start the preloading process, first select the bay where you want to load the material.



If the "Preload filament" Option is disabled, check if there is any other spool loaded in that same port or in the adjacent bay. If this is not the case, please contact the BCN3D support team to reset the feeder system.

- Then select the material you want to preload and press the Continue button. To start using the printer and check that everything works correctly, we recommend using the material that comes included with your equipment: Omega BCN3D Proto Spools.

If you want to load a Custom material you will need to access the OOFL (Omega Open Filament License) menu where you can customize the print head and printing surface temperature parameters.

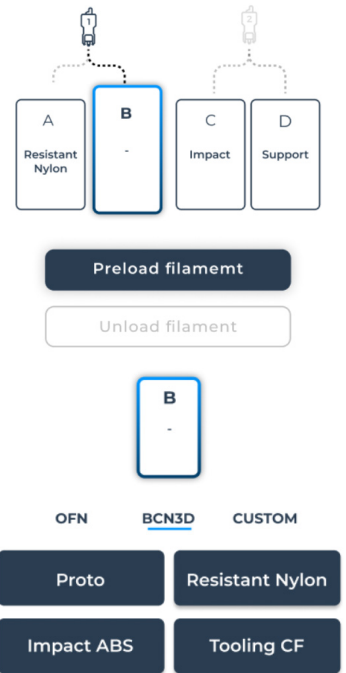

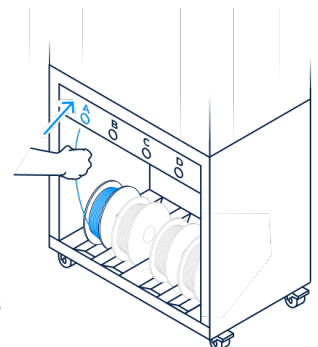

"The BCN3D Omega I60 is open to third-party filaments. To use Custom materials in the BCN3D Stratos slicer, you will need to activate your OOFL (Omega Open Filament License). The license is completely free and will only take a few minutes to activate through the following link:"
<https://3d.bcn3d.com/bcn3d-omega-i60-omega-open-filament-license>
 Check out the following article to learn more about how to use Custom materials in the BCN3D Omega I60 printer.

"Once you have selected the bay and material, the screen will prompt you to insert the filament.
 Cut the filament end at a 45° angle for easier insertion.
 Insert the filament into the loading port and continue pushing the material steadily until you feel that the filament is being pulled by the feeder system. It is normal to feel slight resistance at the point where the tip of the filament activates the FRS (Filament Runout Sensor), do not remove the filament once the FRS has been activated; continue pushing until you notice that the feeder is pulling the material."

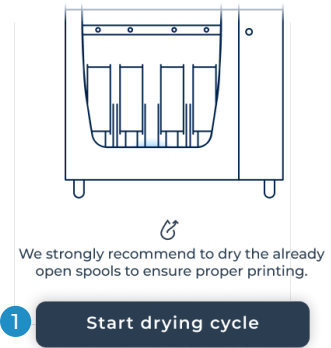

After every material preload, the printer will give you the option to start a spool Drying Cycle. We recommend starting the Drying Cycle if the spool you have loaded has been stored outside of the MOS for a long time, or if it is a new spool with damaged packaging and you are unsure if its moisture level is correct.



 Keeping the filament humidity low is a key factor in avoiding printing problems such as nozzle clogging, poor surface quality, or models that do not meet dimensional or stress requirements.

• **Drying cycle** *(OmegaAssistant/DryingCycle)*

The Material Operation System “MOS” of Omega I60 features a spool recovery system. This allows initiating a drying cycle to reduce the moisture levels of spools that haven’t been stored correctly. Working with materials with low moisture offers better print quality, ensuring that the printed part meets the technical requirements and specifications of the material used. Additionally, it drastically reduces printing errors, providing better reliability and repeatability.

 The MOS drying cycle reaches up to 70°C. Please refer to the Passive Mode section if you want to use low-temperature materials.

You can start the spool drying cycle in two ways:

1. At the end of the loading spool process, the printer will ask if you want to start the drying cycle.
2. You can start it at any time from the Omega Assistant menu.

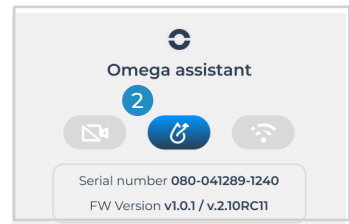

If you start a drying cycle, you’ll be able to see the status of each spool you’ve loaded:

UNKNOWN	If you load a spool but don’t start the drying cycle, the printer will mark that spool as Unknown. This is because it has no way of knowing the moisture level of that spool.
DRYING	If after finishing loading the spool, you click on the “Start Drying cycle” message, the MOS will begin a drying cycle. *All spools that are in “Unknown” state will also switch to “Drying” because the drying cycle will affect all spools inside the MOS.
READY	After 24 hours, the drying cycle will be completed, and the spools will change to “Ready” state.

 Spools that haven’t been properly stored can cause poor print quality or even lead to clogging of the hotend tip. It’s not mandatory to wait for the drying cycle to finish before starting printing, but we recommend waiting at least 4 hours, especially for technical materials or those with fibers.

From this point on, the entire process will be automatic.

- **Loading** - The Feeder will start loading the material until it reaches the print head extruder.
- **Heating** - At that moment, it will verify that the print head temperature is correct for insertion. The screen will display the temperature of the print head so you can check that the temperature is correct for the material you have loaded. The printing surface will also start heating.
- **Inserting** - The filament will be pushed by the print head extruder, reaching the hotend where it will heat up, and the printer will purge a certain amount of material. You can check that the material comes out of the hotend tip smoothly without any obstructions.
- **Cleaning** - Once the filament is inserted and some material is purged, the printer will clean the hotend tip with a series of movements through the silicon cloth.
- **Mesh mapping** - If the print is in single or dual mode, the printer will sense multiple points of the build plate to compensate their Z offsets during the print.
- The 'Filament Loaded' screen will indicate that the loading process has been completed successfully.



Unloading filament *(Setup/MOS/Unloadfilament)*

When the print is finished, the filament will be unloaded back to its preloaded position. The unloading process is fully automatic, the printer will perform the following steps:

- **Extraction** - The filament will be extracted from the print head.
- **Unload** - The feeder will pull the material and the spool coffin will rewind the spool back to its preloaded state.

To unload a material spool, simply select the bay you want to unload and press the 'Unload' button.

The Feeder system will unlock the filament so it can be easily removed.

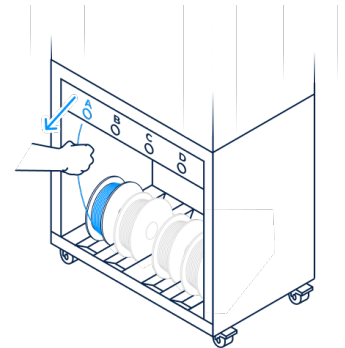

- Passive Mode**

If you load a low-temperature material from the Custom materials menu, the printer will automatically detect when the configured temperature is below 230°C. At that moment, it will notify you that any ongoing drying cycle will stop, and the MOS will switch to Passive Mode.

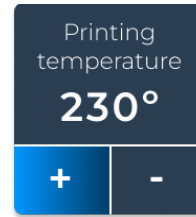

 Low temperature material detected. The drying cycle will be disabled.

Passive mode will perform the same recovery cycle but at a temperature of 50°C. This serves two purposes:

Firstly, it maintains the humidity below 10% for at least 10 days if the door is not opened. Therefore, any spool that was dry in the Ready state will remain at safe moisture levels for several days.

On the other hand, it ensures that any low-temperature spool, such as PLA, will not be affected, and printing can be done without any traction issues.

You will notice that the MOS has switched to Passive Mode because instead of showing the information of each spool, they all display the message "Passive Mode" both in the quick access dropdown menu and below each bay.

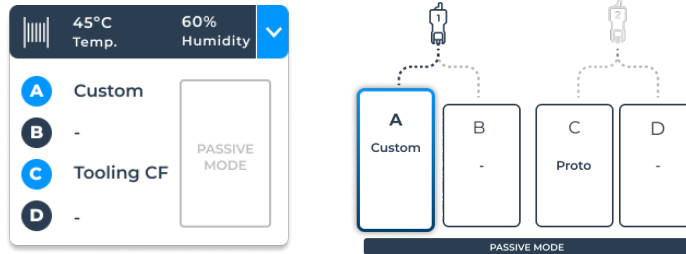

- Exit Passive Mode**

The easiest way to exit the Passive Mode is by starting a drying cycle from the Omega Assistant menu by clicking the "Start drying cycle" button. If there is a low-temperature spool loaded, the assistant will show you a warning message as these could be damaged.

The other way to exit passive mode is by unloading all the low-temperature spools that are loaded in the MOS. At the moment when all the low temperature spools have been unloaded, the printer will detect it and display a popup informing that a drying cycle can be started.

Keep in mind if you have spools inside the MOS that are not loaded, just stored, as the printer will not detect them.

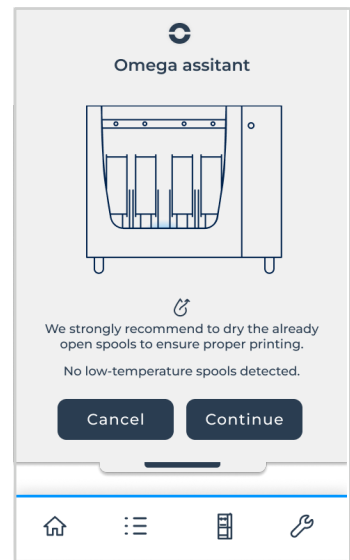



Settings

In the Settings menu, you can configure and modify most of the default parameters of your printer.

- **General** *(Settings/General)*

From the General Settings section, you can check your printer’s model and version.

If your printer is not registered, the product registration button will be displayed. Once registered, if the printer is network connected, you should see the email account of the user that registered the equipment.

Not registered:



BCN3D Cloud registered:
Usermail@bcn3d.com



No info
Check the network connection

You’ll also find information about the firmware version installed on your printer. Keeping the printer connected to the internet allows it to detect new versions and show you important update alerts. It’s crucial to keep both the firmware version and the BCN3D Stratos Slicer version up to date to avoid printing issues.

Firmware version:
1.0.0
Available version:
1.1.0



Firmware version:
1.1.0
Available version:
None

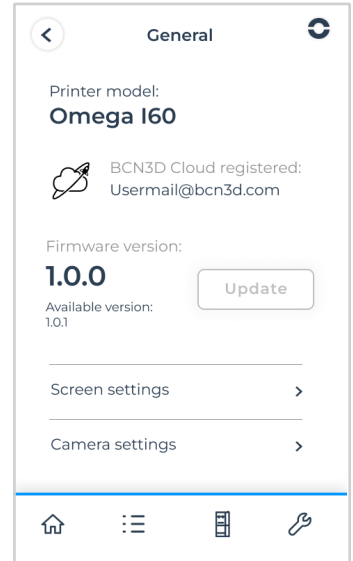

In addition, you will be able to configure the screen settings and the camera.

- **Calibration** *(Settings/Calibration)*

All BCN3D printers come pre-calibrated from the factory, however, after transportation, when they are installed for the first time, it may be necessary to run a calibration routine.

When installing the printer, it is necessary to level it and adjust the leveling feet. This way, it will reduce vibrations, and it will not be necessary to recalibrate the printer so frequently.



The BCN3D Omega I60 uses the hotend tip to perform the necessary measurements in the calibration routine. For this reason, it is crucial that the hotend tip is always clean to prevent material blobs from causing false measurements. The printer has different cleaning systems and routines to avoid this problem, but periodic maintenance by the user will always be necessary. To prevent erroneous measurements, make sure that the hotend tip is tightly secured. Manual tightening is sufficient; never use tools to tighten the hotend tip.

*Please refer to the Maintenance section for more information.

Calibration and hotend tip change

If the nozzle change process is done carefully, following the assistant’s instructions, it should not significantly affect the XYZ axis offsets between both print heads.

**Please refer to the Hotend Tip Change Routine (Page 32) for detailed information.*

However, depending on how tightly the hotend tip has been screwed, it may have altered the Z offset. This is why we recommend performing a Z Axis Auto Calibration as explained below.





If after calibration you find that the Z offset is greater than 0.05 mm, check that both nozzles are securely tightened. Manual tightening is sufficient; never use tools to tighten the hotend tip.

Z Axis Auto Calibration *(Settings/Calibration/ZAutoCalibration)*

This calibration process allows calculating the height difference between the two print heads. During the manufacturing of your printer, the height of the print heads has been adjusted and calibrated to ensure that the offset between them is shorter than 0.05mm.

However, with use, it may be necessary to recalibrate the printer to determine this height difference. The printer will automatically correct this offset depending on the printing mode, as needed.

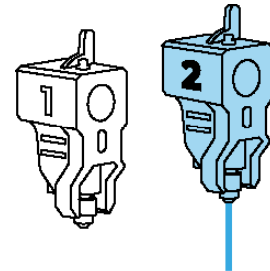

The Z-axis calibration process is fully automatic. The printer will perform the following routine:

1	Preheat printing surface	Set printing surface temperature to 45°C
2	Cleaning routine Printheads 1 and 2	Both print heads will be heated to the temperature of the loaded material, and the cleaning process will begin until reaching 145°C. The speed and frequency of the cleaning movements have been optimized to ensure that no material blobs remain on the hotend tip at the end of the cleaning routine.
3	Measurement Printheads 1 and 2	Once the temperatures of both hotends have stabilized, a Z-axis measurement will be performed at the center of the printing surface, one with the left print head and another with the right, thus calculating the height difference between print heads.
4	Save Z offset	When pressing the Success button, the new XY offsets will be saved in the printer.

XY Axis calibration *(Settings/Calibration/XYCalibration)*

The XY Axis Calibration allows establishing the distance between the nozzle of both print heads. This adjustment is performed on all BCN3D printers during manufacturing and is only necessary redoing it if you want to use Dual printing mode.

**The Single Left, Single Right, Mirror, and Duplication modes do not take into account the offset between print heads on the XY axes.*

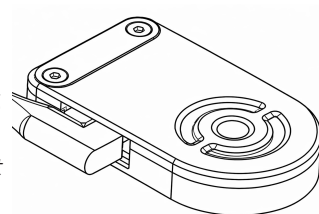

Automatic Camera XY axis calibration

The fastest way to perform an XY calibration is through the camera installed on the right, next to the printing surface. Once executed, the printer will perform following steps:

1	Cleaning routine printheads 1 & 2	Both print heads will heat to material temperature, the build plate will be lowered and both print heads will come forward to be cleaned via brass wiper
2	XYZ homing	The print heads will perform a new XY homing, then the left print head will sense the Z position of the XY camera calibration plate
3	XY sensing	The left print head nozzle will be positioned on the XY camera objective, the camera image will be displayed on screen
4	Offset calculation	The printer will automatically calculate the XY print head offsets via image recognition.
5	Save XY offsets	When pressing the continue button, the new XY offsets will be saved in the printer

Manual Camera XY axis calibration

If the automatic method fails to recognize the nozzle tips, it will ask the user to center them relative to the camera through screen input. With this method, only step 4 is different:

4	Offset input	Change the nozzle position through the arrows on screen until it is centered. Then repeat the same process with the right print head
5	Save XY offsets	When pressing the continue button, the new XY offsets will be saved in the printer

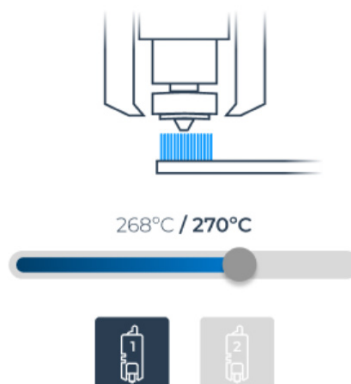
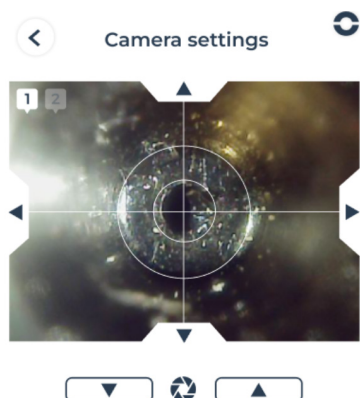

You can check the XYZ offsets recorded by the printer in the calibration menu.

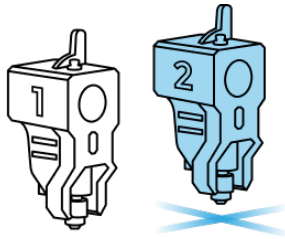

Current offsets of print head 2 relative to 1

X	Y	Z
+572.4	-0.01	-0.03

Manual XY calibration through print

If the XY camera feature is not available, you can still perform the XY calibration by printing a series of calibration lines with both print heads. For this reason, make sure to load material into both print heads before executing the XY calibration routine. Also ensure that the Z offset between print heads is lower than 0.05mm. The printer will perform the following steps:

1	Preheat printing surface	Set printing surface temperature to Loaded Material Temp.
2	Cleaning routine Printhead 1	The left print head will be heated to the temperature of the loaded material and then will start the cleaning routine until the temperature drops 70°C. The speed and frequency of the cleaning movements have been optimized to ensure that no material blobs remain on the hotend tip at the end of the cleaning routine.
3	Z Homing	The printer will perform a Z home measurement to position the printing surface correctly for printing the calibration lines.
4	Print Y Axis Calibration lines	A set of lines will be printed with both print heads to determine the Y offset. The user must select on the screen the lines that match. If none of the lines match, the user can clean the printing surface and click on the Redo option to print a new set of lines.
5	Print X Axis Calibration lines	Next, the set of lines for the X offset will be printed. Select the matching lines following the same criteria as before. And select the Redo option if necessary.
6	Save XY offsets	When pressing the Success button, the new XY offsets will be saved in the printer.

Operation

Considering that the printer is connected to the network, registered, loaded with material in both extruders and correctly calibrated in the X, Y and Z directions, this chapter focuses on the preparation of the model to be printed.

Preparing a print

BCN3D Stratos

BCN3D Stratos is a free and easy-to-use 3D printing software that prepares your digital model for 3D printing. Such a complex process has been carefully optimized and tested for BCN3D products. As a result, the user enjoys a flawless 3D printing experience while increasing the reliability of the process.

BCN3D Stratos includes validated printing profiles to increase the printing success rate. Just select the installed hotend tips and materials on the printer to get the right set of parameters.

Installing BCN3D Stratos

Visit the [Knowledge base](#) to download the suitable version of BCN3D Stratos for your Operating System. Once downloaded, follow the installation wizard.



Watch our video to learn how to get started with BCN3D Stratos



Add printer

After the installation, when opening BCN3D Stratos for the first time, you will be asked to select your BCN3D Omega I60 printer.

Add an offline virtual printer

- Select the Omega I60 profile

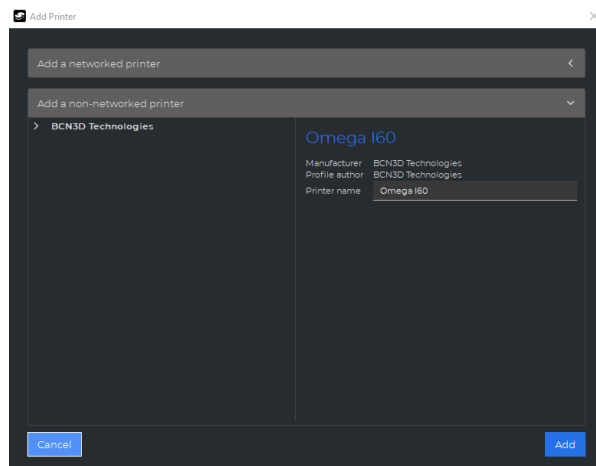

Add a printer that is linked to your account

- To add a printer into BCN3D Stratos and take profit of all BCN3D Cloud functionalities, the printer must be registered and have an internet connection, as indicated in the sections [Network connectivity](#) and [Register](#).
- Sign-in in your BCN3D account.

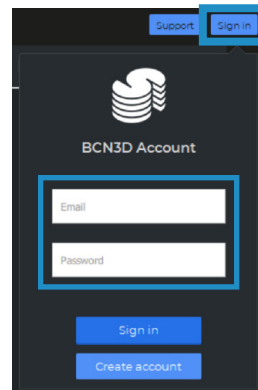

- Select the printer you want to print with.

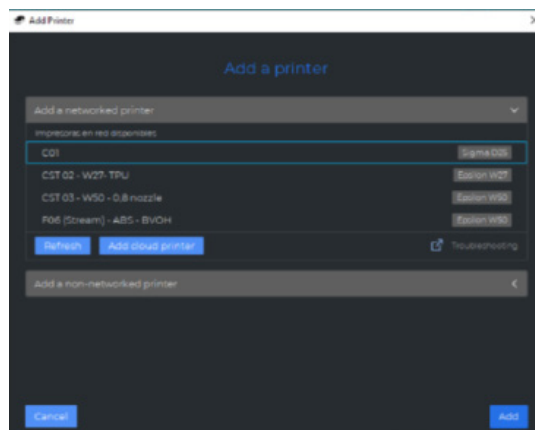

Printing modes

BCN3D Stratos takes advantage of all the benefits of the IDEX system: simply merge multi-material models, generate support structures, cut down printing times by combining hotends with different nozzle sizes or even double production capacity thanks to duplication and mirror mode.



Visit [Learn](#) to know more about success stories, learn about our latest updates, whitepapers and more.

Before selecting any printing mode, open a file using the button with the folder icon or through to the File > Open menu and select the file to be printed. Benchmark models can be found in the [Sample parts](#) folder.

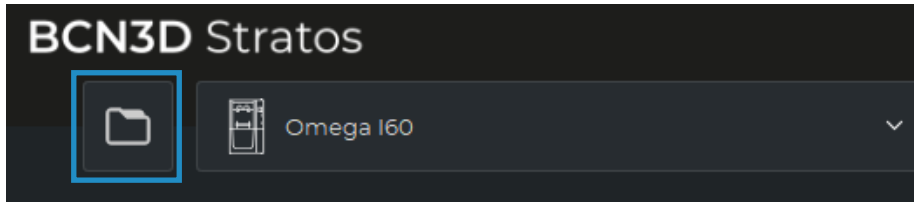

In BCN3D Stratos, the printing modes can be easily selected on the side bar when there are models on the build plate (A) or on the settings selector (B):

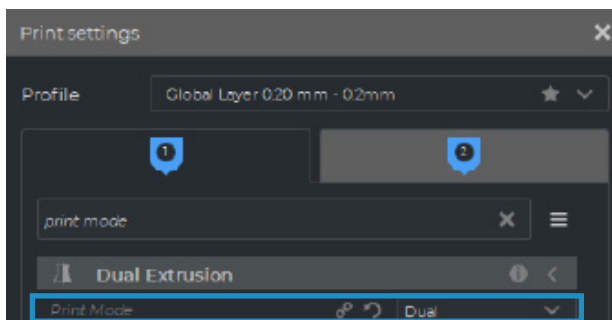
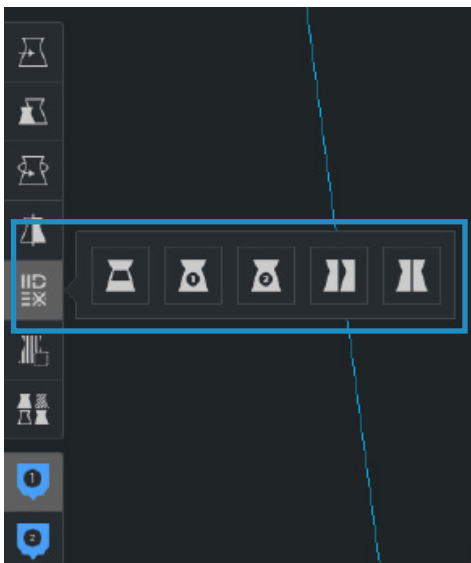

Dual

- Select Dual in the Print mode list option or the corresponding icon.

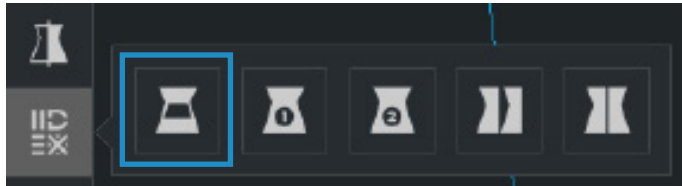

- Click on each part and assign it to the extruder to print with.

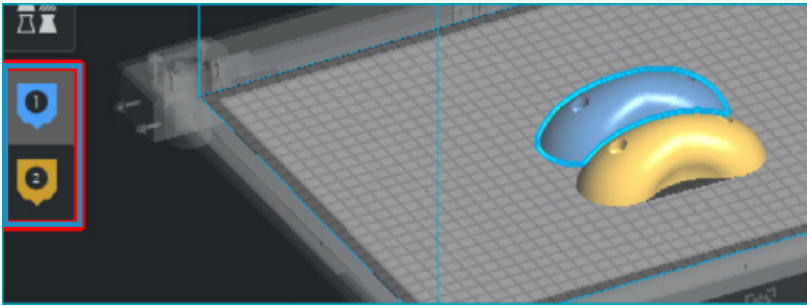

- Select the material and hotend loaded on each extruder.
- Select the models by Shift+Left Click. Selected models will be highlighted with a blue outline. Right click on any of the selected models, and select *Merge Models*.

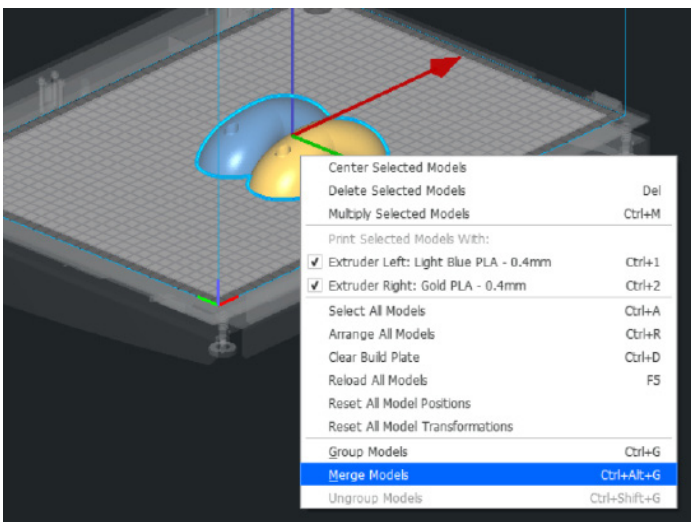

- Select your preferred *Profile*.

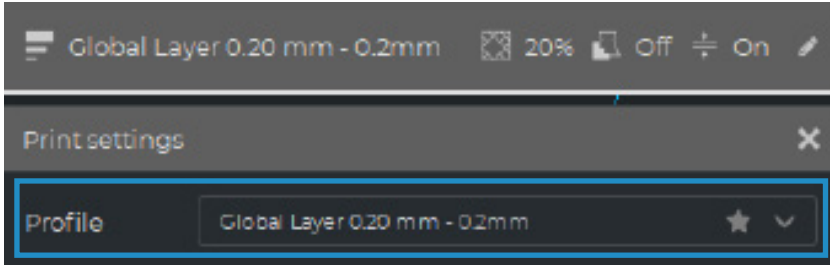

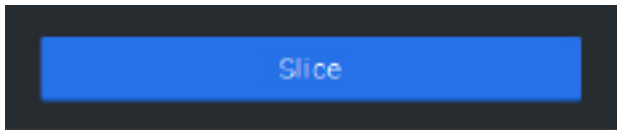

- Click *Slice* to generate the printing file.

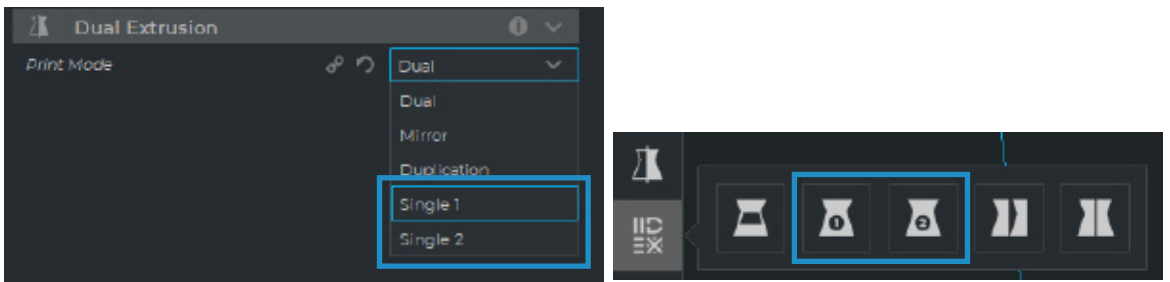

Single 1 and Single 2

- Select *Single 1* (if you only want to use the left extruder) or *Single 2* (if you only want to use the right extruder) in the Print mode list option or the corresponding icons.



 When selecting these modes, the other extruder will be disabled automatically, selecting the correct settings for single prints.

- The software will automatically assign the model to print with the selected extruder.
- Select the material and hotend loaded on the extruder.
- Select your preferred Profile.
- Click *Slice* to generate the printing file.

Duplication

Print the same model with both print heads simultaneously and double the printing capacity. This mode is ideal for short runs of production. Bear in mind the available build plate will be reduced by half.

- Select *Duplication* in the Print mode list option or the corresponding icon.

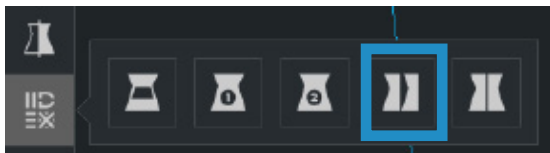
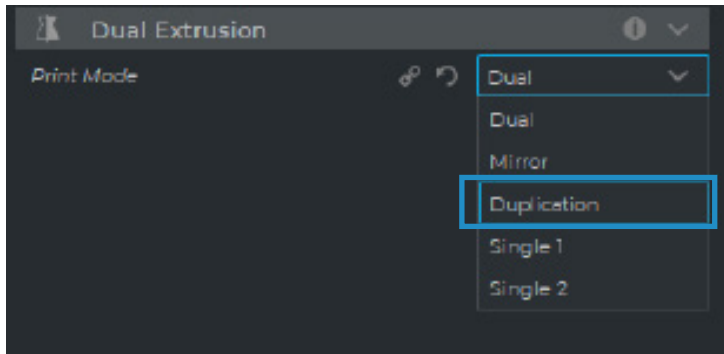

i Note how the available printing volume is reduced and the loaded models automatically move to the left. These models can still be modified. A preview of the duplicated or mirrored parts is available at the right.

- The software will automatically assign the model to print with the extruder 1 (left) and disable the extruder 2 (right).
- Select the material and hotend loaded on the extruder 1. This will be the material chosen for printing both parts simultaneously.
- Select your preferred *Profile*.
- Click *Slice* to generate the printing file.

Mirror

Print the model and its symmetrical part (along the X axis) at the same time. Using this printing mode, the printing capacity is doubled, but the available build plate is reduced to less than half the original size.

- Select *Mirror* in the Print mode list option or the corresponding icon.

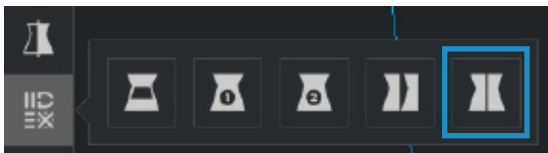
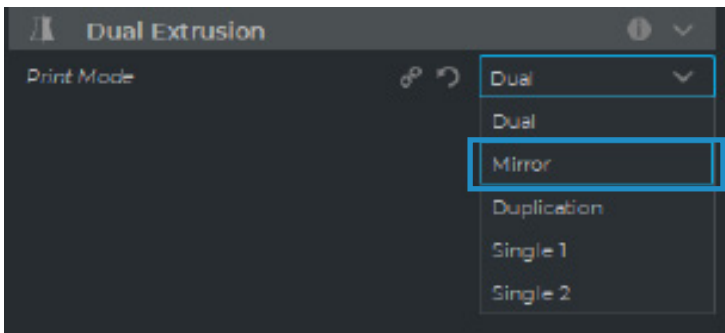

i Note how the available printing volume is reduced and the loaded models automatically move to the left. These models can still be modified. A preview of the duplicated or mirrored parts is available at the right.

- The software will automatically assign the model to print with the extruder 1 (left) and disable the extruder 2 (right).
- Select the material and hotend loaded on the extruder 1. This will be the material chosen for printing both parts simultaneously.
- Select your preferred *Profile*.
- Click *Slice* to generate the printing file.

Maintenance

Maintenance tasks should be performed periodically to keep the equipment in optimal working condition. The maintenance table below indicates the tasks that need to be performed and how often they should be done. You will also find a detailed explanation of how some of the maintenance tasks should be performed.

Maintenance Schedule

Weekly *When necessary	Clean the hotend tip	Manually move the print heads to the front of the printer. Heat the print heads using the preheat menu, and with the help of the metal brush included in the toolkit, clean the hotend tip, removing any adhered material.
	Empty the purge buckets and clean the printer	Keep the printer clean by removing any filament residue on the print platform or gantry system. Empty the purge buckets and ensure proper alignment of the silicone cloth with the nozzle when reinstalling them. *Refer to page 24 for further details.
Every 3 months *1000 printing hours	Clean extruder drive gears	Use the metal brush to clean the drive gears. This will ensure proper filament traction.
	Check print head fans	Check that the three fans on each print head are working correctly. Clean any accumulated dust with compressed air and a microfiber cloth.
	Check the hotend tip cover	Check the condition of the hotend tip covers. If it is damaged, replace it with a new one provided in the toolkit.
	Check the silicone cloths	Check that the hotend tip passes at the correct height through the silicone cloth. If the silicone cloths are damaged, replace them with new ones.
	Check belts tension	The Omega I60 features an automatic belt tensioning system. If you detect that the belts are loose, contact support.
	Lubricate X/Y linear guides and Z axis screws.	Clean the linear guides with a paper towel, apply the liquid lubricant from the toolkit to the rails, and use high-temperature grease on the two Z-axis screws.
Yearly *3000 printing hours	Check bowden tubes	Filament, especially fiber-filled materials, wear down the Bowden tube interior, increasing friction and possibly causing extrusion issues. Replace the Bowden tubes if needed.
	Change HEPA filter	To ensure proper air filtration, it is necessary to replace the HEPA filter annually.

Replacement Consumables

Refer to the Replacement Consumables table if you need a specific component from your local distributor. Please use the reference code when ordering the replacement parts.

SKU Reference	Component
20527	Hotend Tip 0.4 HR
20528	Hotend Tip 0.6 HR
20531	Omega Hotend Tip 0.4 HF
20532	Omega Hotend Tip 0.6 HF
20102	Omega Flexible Printing Surface (textured)
20554	Omega G2 Upper Bowden Tube (1200mm)
20555	Omega G2 Lower Bowden Tube (800mm)
20530	Brass Wiper Omega
20652	Silicone Cloth Omega
20646	Hotend Tip Sock Pack (10u) - Light blue
20647	Hotend Tip Sock Pack (10u) - White
20675	Hotend Tip Sock Pack (10u) - Dark yellow
20676	Hotend Tip Sock Pack (10u) - Dark red
20352	Omega I60 Hepa & Carbon Filter
20125	Y Belt
20124	X Belt
29040	Guide Lubricant Omega

Maintenance routines

Clean the hotend tip. (Weekly routine)

Keeping the hotend tip clean is key to ensuring correct calibration and measurement of the printing surface. This results in a well-adhered first layer.

The printer has automatic cleaning routines that prevent material residues from accumulating on the hotend tip, but it is still advisable to periodically perform a manual cleaning of the hotend tip.

To manually clean the hotend tip, follow the steps outlined below:

- Preheat both printheads from the menu: PrinterSetup/PrintHead/Preheat.
- Manually move the printheads to the front of the printer.
- With the help of the metal brush included in the toolkit, clean the nozzles by removing any filament residue.
- Stop the preheating routine and wait for the hotend tips to cool down.
- Finally, before printing, ensure that the hotend tip is correctly tightened all the way in.

Empty the purge buckets and clean the printer. (Weekly routine)

Keeping the printer clean prevents operational issues. It is important to avoid the accumulation of filament in the purge bucket and ensure there are no material residues on key components of the machine.

You can use a vacuum cleaner to collect any filament residue, checking the pulleys and belts, as well as the linear guides, removing any filament residues that might be stuck.

Keep the base of the heated chamber clean, ensuring there is no material accumulation on the ventilation outlet.

Clean the extruder drive gears (Every 3 months)

With use, there may be filament dust residues accumulated on the drive gears of the extruder motor, which can cause underextrusion issues. To remove them follow the steps outlined below:

- First of all, unload the material from the printhead you want to clean.
- Once unloaded, release the extruder motor lever by moving it to the left.
- Disassemble and set aside the printhead cover by removing the two screws located on the left side.
- Now remove the 4 screws that cover the extruder motor.
- Clean the drive gears with the help of a metal brush; you can also use a paintbrush or compressed air.
- Reassemble all the components in reverse order and make sure to put the extruder lever back in the vertical position (*3 clicks).

BCN3D Technical Assistance Services

Technical Assistance

You can contact the technical assistance services by email, and we will answer you as quickly as possible. Please remember to include your phone number so we can contact you.

omega-assistance@bcn3d.com

Email

If you have a question that is not related to technical assistance, please send us an email to the address below. A BCN3D Technologies expert will contact you as quickly as possible.

info@bcn3d.com

You can find all of this information in the Contact Section of our website:

<https://www.bcn3d.com/contact-us/>

Be sure to include the serial number of your printer whenever you send us a query to help us provide the best possible services.



If you do not find a solution to your problem in this manual, please contact the BCN3D Technologies support team through [Contact Support](#)

Terms and conditions

Overall Vision

The terms “we”, “us” and “our” refer to BCN3D Technologies. The terms “you” and “your” refer to the person or entities that purchase any service or product. BCN3D Technologies offers all the information about products, tools, and services available, always conditioned to the acceptance of all the terms, conditions, policies and notices that are specified below. By purchasing one of our products, you will be accepting our terms and conditions, including the additional terms and conditions and the policies mentioned in this document.

Return policy

BCN3D accepts returns for refunds or exchanges, subject to the following:

1 Withdrawal right

You have 14 days from the date of reception of the product to execute the right of withdrawal. In order to request a return, the product must not have been opened, it should be closed and sealed inside its original box. If you have opened the product, it will not be eligible for a refund. This said, the transport costs (both shipping and return, in addition to possible customs fees if the merchandise comes from outside the European Union) will be responsible of the customer and deducted from the amount to be returned.

Requirements:

- Having acquired the product through **BCN3D Technologies**
- Be within the established deadline, **which is 14 calendar days from the reception** of the order.

2 Defective goods

If you detect any defect in the operation of the product, you have 7 working days from the reception of the product to communicate this defect and proceed to its return.

You should contact the support department by email through omega-assistance@bcn3d.com or by phone +34 935 95 43 43, to notify this incident.

In this case, BCN3D Technologies will be responsible for all the transportation costs.

In cases of wear or tear of the product due to causes that are not exclusively of its use, BCN3D Technologies reserves the right to accept or reject the return of the product, in addition to establishing the conditions of such return or substitution of the product.

3 The product received has been damaged during transport

The client will have 24 hours to verify and communicate the integrity of all the components of the order and verify that all the pertinent goods are included within the total set of the demanded product. An order will be considered delivered when the delivery receipt is signed by the customer.

Upon receiving the goods, you must ensure the external package is in good conditions and shows no symptoms of having received a blow. If the package has any sign of having received a blow or any other damage, you must reject it, reflecting it on the delivery note of the carrier and notifying the support department by email (omega-assistance@bcn3d.com) during the following 24h.

How to make a return?

In order to make a return first, you will have to contact us to omega-assistance@bcn3d.com, explaining the reason of your willingness to return or substitute one or more products.

- You will receive a document by email to be completed (RMA), so that we can authorize the return.
 - Once the RMA is completed, you must send it to omega-assistance@bcn3d.com duly completed.
 - The after-sales department will assess the situation and within 48 hours will tell you whether or not we accept your return request. If accepted, it will assign you an RMA number with a validity of 30 days.
 - The product must be sealed in its **original packaging**. In the case of not returning the order in its original and sealed packaging, BCN3D Technologies reserves the right to accept or reject the return or establish a depreciation of the product.
 - Once the product has been packed, we will send a transporter that will pick up the goods to be returned perfectly packed, being able to desist from the collection in case of improper packing. It is important that you place the **RMA number visible on the package**.
 - You will not have to pay anything to the courier, except if the withdrawal right is applied (first case), where the cost of the carriage will be deducted from the amount to be returned; or in case the damages produced in the products are not caused by the transport or are not a manufacture defect. In all these scenarios the customer will be responsible for the shipping costs.
- Once the goods are received in our facilities, our technical service will inspect them and determine whether the return is accepted or not.
 - The refunds will be carry out between the 1st and 10th of the month according the return acceptance. For example, if the return becomes effective on April 15, the money will be paid between May 1 and May 10.
 - In case of not accepting the return for damages produced outside BCN3D Technologies responsibility, you will be given the option to repair the product or return it as it is. Both the repair and shipping will be borne by the customer.

Open source

Open source is a development model that promotes universal access by granting software licenses free of charge, and also universal distribution, including subsequent improvements.

We believe that adopting an open source philosophy offers many advantages:

- **More control:** We can see everything that is happening with the source code, designs etc., and modify them to suit our needs.
- **It helps us learn:** We can see and read the software designs that other people have made, which helps us to become better programmers and engineers.
- **Safety:** Since the designs are open designs, a lot more people can modify and/or correct any errors that the original programmer may have made.
- **Making improvements quickly:** The open source community provides a lot of information about how to improve the product. This helps us to fix errors and update programmes much more quickly.

Using open source licenses for the products we develop is a way of expressing our willingness to share, to collaborate with other people in a transparent way (so that others can see what we are doing and join in), to embrace failure as a means of improving, and to expect, even encourage, everyone else to do the same.

BCN3D Technologies and its products would not be where they are today without the RepRap project and its open source community. The RepRap project started out as an initiative whose objective was to develop a 3D printer which could print most of its own components and be a low-cost printer. As an open source project, all of the designs produced by the project have been released under a free software General Public License (GPL).

This project does not only include hardware, but has been conceived as a complete ecosystem of tools for printing, from the CAD/CAM software to the code read by the machine to print physical objects.

BCN3D Omega I60 printers use many open source tools and technologies, such as Marlin software and the Stratos pre-processed software. The first controls all the printer's components, while the second converts the 3D file into G-code, a language the machine is able to understand.

Marlin firmware is published under a GPL license. This means that we must keep Marlin open, and must provide our source code to end users. For this reason we have our repository on the Github platform, where we post all the changes we make.

Stratos software is published under an LGPLv3 license. This is the same as the GPLv3 general license but a paragraph has been added to Section 13 which makes it obligatory to provide source code to those who use software through a network. We therefore have repositories for each operating system so that users can access the source code.

Open Source is not only used for code, but also covers hardware. In our case all the mechanical and electronic parts are published under a GPLv3 license.

BCN3D Technologies is firmly committed to open source initiatives, and we believe that with the help of the community we will be able to make better products.

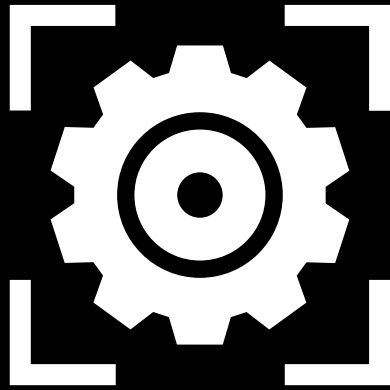

BCN3D